



# **Nuraply 3P Covered Membrane Installation Manual**

**Nuralite Waterproofing Limited**  
[www.nuralite.co.nz](http://www.nuralite.co.nz)

*This manual is designed for installing covered membranes or waterproof tanking below the ground level of a building.*

*Buildings with deep multi-storey basements and in particular when subject to constant hydrostatic pressure present, specialist design and installation problems which are not covered by this manual.*

**2019 Edition v1**

**March 2019**

## **NURAPLY 3P COVERED MEMBRANE INSTALLATION MANUAL**

---

### **TABLE OF CONTENTS**

1. Statement of Use & Limitations .....	5
2. Product Overview .....	7
3. Nuraply 3P Covered Membrane System Components .....	9
4. Health and Safety .....	16
5. Project Administration/Supervision .....	17
6. Nuralite Site Requirements .....	18
7. Installing the Nuraply 3P Covered Membrane system .....	19
a) Underslab Membrane.....	19
b) Walls And Foundations Membrane.....	20
c) Greenroof Membrane .....	22
d) Carpark Deck Membrane .....	27
8. Post Membrane Installation.....	30
a) Drainage behind the wall (by others) .....	30
b) Greenroof Drainage, Soil Substrate & Plant Installation – (by others).....	30
c) Car Park Overlay Installation – (by others) .....	31
9. Substrate Readiness Checksheets .....	32
10. Installed Product Checksheets .....	37
11. Data Sheets .....	40
12. Installation Details .....	73

### **Document Control**

Issued John Simmons

March 2019 2019 Edition V1

The only person authorised to change this plan is the Managing Director, John Simmons.

## **NURAPLY 3P COVERED MEMBRANE INSTALLATION MANUAL**

---

Nuralite waterproofing systems are intended for application by trained and approved installers. A listing of the current approved applicators are available at [www.nuralite.co.nz/Applicators\\_By\\_Region/](http://www.nuralite.co.nz/Applicators_By_Region/). These notes are a technical guide to the application of the Nuraply 3P covered membrane system (which includes Nuraply 3PT, 3PTM, 3PG & 3PC). The Nuralite organisation also maintains a team of skilled technical representatives who are prepared to demonstrate the correct application of Nuraply 3P system on site or to discuss any problems which may arise regarding its use.

Please note that Nuraply has a long product defects warranty period and every precaution must be taken to avoid any possible installation faults. Application according to these guidelines must be insisted upon by the Applicator to ensure that full benefits of the warranty period are maintained.

### TECHNICAL ADVICE

For advice on unusual or abnormal conditions or details, please contact Nuralite Waterproofing Ltd,

Phone: 09 579 2046, 0800Nuralite, or  
Email: [info@nuralite.co.nz](mailto:info@nuralite.co.nz)

### OTHER REFERENCE DOCUMENTS

This manual forms one part of the full technical documentation for the Nuraply 3P system.

Technical literature (available at [www.nuralite.co.nz](http://www.nuralite.co.nz))

- Nuraply 3P covered membrane system detail drawings
- Material Safety Datasheets
- Technical Datasheets

Specifications

- Generic Nuraply 3P covered membrane system specifications
- Project specific specification

## NURAPLY 3P COVERED MEMBRANE INSTALLATION MANUAL

The Nuraply 3P Covered Membrane System complies with the New Zealand Building Code.

As an explanation of compliance with Building Code criteria under s269 (1) of the Building Act 2004 –

Clause B1.3.2	Compliance has been established by testing to ensure that tensile strength, elongation, compression, and seam strength are adequate.
Clauses B1.3.3 (b), (e) & (m)	Compliance has been established with testing to ensure resistance to water absorption, hydrostatic pressure, earth pressure, differential movement over substrate joints are adequate and vegetation (3PG).
Clause B2.3.1 (a) & (b) if exposed	Unexposed, the Nuraply 3P covered membrane system is assessed for at least a 50 year durability period as part of the envelope building elements as it does not degrade when buried. Exposed elements are assessed for 15 year durability period based on in-service history in excess of this period.
Clause B2.3.2 (a)	The membrane is not installed over elements with lesser durability than 50 years.
Clause E2.3.1	The roof membrane system will repel water from entering building and drainage paths ensure it can shed precipitated moisture and melted snow.
Clause E2.3.2	The membrane system prevents the penetration of moisture as it has been tested for water absorption, vapour transmission, hydrostatic pressure and joint seam strength to satisfy this requirement.
Clause E2.3.3	The membrane system does not absorb or transmit moisture so protects the building elements from dampness or damage.
Clause E2.3.7 due allowance has been given to;	
(a)	The consequences of failure have been considered through specified repair and maintenance requirements, multiple drainage paths and the ability of the system to tolerate ponding (standing water three days after cessation of flow)
(b)	The effects of any uncertainty in or from the sequence of construction can be accommodated.
(c)	Variation in the properties of materials and in the characteristics of the site are accommodated. The membrane has a tolerance for substrate variations and environmental factors.
Clause F2.3.1	No gases liquid or particles are emitted by materials that could give rise to harmful concentrations on surfaces or in atmosphere of any space.

Compliance with other clauses have been considered and found not applicable.



## 1. Statement of Use & Limitations

### *Use*

Nuraply 3P covered membrane system provides a durable waterproofing system for installation by approved installers on below grade walls, beneath floor slabs and Greenroofs and carpark decks. The system covers the products Nuraply 3PT (for walls), Nuraply 3PTM (for beneath floor slabs), Nuraply 3PG (for walls near plants and Greenroofs) and Nuraply 3PC (for carpark decks).

### *Limitations*

Installation is in accord with this manual Nuralite 3P Covered Membrane Installation Manual 2019 Edition 1 available on the Nuralite website and the Nuraply Waterproofing Membrane Building Product Quality Plan 2018 v1.

Only on a structure complying with the New Zealand Building Code. It may be installed directly onto the following substrates:

#### Under slab - 3PTM

- compacted hardfill up to 600mm in depth installed complying with the requirements of NZS 3604 (2011) or site concrete

#### Walls - 3PT and 3PG

- concrete substrates complying to NZS 3101 (2006)
- concrete block surfaces NZS 4229 (2013) with mortar joints flush.

#### Greenroofs – 3PG

- H3.2 treated Timber\*, including plywood sheets and reconstituted wood panels (Strandboard), substrates complying to AS/NZ 2269 (2012) (directly or with Enertherm PIR Boards between) with treated timber\* trim, battens and framing where timber is detailed and Nuralite product is directly applied or
- concrete substrates complying to NZS 3101 (2006) (directly or with Enertherm PIR Boards between) or
- NPM 900 metal tray decks with Enertherm PIR boards between.

#### Cardecks – 3PC

- concrete substrates complying to the performance requirements of NZS 3101 (2006)

\* All timber products must be treated but must not be treated with LOSP (light organic solvent preservative) nor CuN (copper nitrate).

The design and construction of the substrate, control joints, junctions and allowances for ventilation, movement, condensation control, soil composition and plant selection, framing timber, metal overflashing, cladding, fascia and fire safety provisions is specific to each building, and therefore is the responsibility of the building designer and building contractor. These matters are all outside the scope of this CodeMark.

---

## **NURAPLY 3P COVERED MEMBRANE INSTALLATION MANUAL**

---

Product selection and system design is the responsibility of the specifier. Before making their selection they must consider

- likelihood of hydrostatic pressure and
- natural ground is free of contaminants and
- whether trees or plants may be located adjacent to building where their roots may damage the membrane. In this case Nuraply 3PG should be used as an alternative to Nuraply 3PT.

The Nuraply 3P covered membrane system must be installed with suitable wall drainage and membrane protection in place when used on walls. The underslab substrate must be prepared with compacted sand blinding or site concrete on compacted hard fill.

The Nuraply 3P covered membrane system is capable of withstanding 2 head (20m) of water pressure. However in situations of hydrostatic pressure which may not be drained, such as below sea level or the watertable, the products may be used only in conjunction with specific engineering design. In these cases Nuralite must be consulted for specification and design input before work commences.

Nuraply 3PC membrane is a tough, reinforced, bituminous product for waterproofing concrete substrates. The trafficable surface may have hotmix asphalt laid directly on the Nuraply 3PC or concrete separated from the Nuraply 3PC with a heavy duty polyethylene slip layer. The installation of these are outside the scope of this Codemark.

Above Nuraply 3PG, a layer of heavy duty black polyethylene must be installed prior to installing drainage layers and plants or ballast. This protects the membrane from damage during installation of the Green Roof components. The installation of these are outside the scope of this Codemark. Potable water must not be collected from Green Roof areas.

Exposed membranes, such as at upstands, must be protected with a Nuraply 3PTM capsheet.

The system may be installed in all NZS 3604 Wind Zones, up to and including Extra High.

The slopes allowable are clearly set out in the table on page 6. For low slope roofs the designer of the substrate should take into account the intended use of the roof or deck to ensure continued compliance with the Building Code.

All Greenroof and Carpark projects designs must be certified by an independent engineer that the building structure can sustain the installed loads.

When used on existing projects, it is the responsibility of the property owner to have the structure and substrate assessed by a suitably qualified person and to the satisfaction of Nuralite Waterproofing Ltd. For this Codemark to be applicable the substrate material is limited to only those approved within this manual.

Attention must be paid to application temperature ranges, the necessary requirements for storage of products and their use by dates.

The membranes must be installed only by Nuralite Waterproofing Ltd approved installers.

Any construction details outside those listed in this manual are outside the scope of this CodeMark.

## 2. Product Overview

This manual is designed installing covered membranes on carpark decks and greenroofs, or tanking of below grade level of a building which is wholly or partly below ground. Buildings with deep multi-storey basements or constant hydrostatic pressure present specialist design and installation problems which are not covered by this manual.

The membranes are capable of withstanding 2 head (20m) of water pressure. However in situations of hydrostatic pressure which may not be drained, such as below sea level or the watertable, the products may be used only in conjunction with specific engineering design. In these cases Nuralite must be consulted for specification and design input before work commences.

Alert Nuralite if you have concerns about the environment or localized watertable.

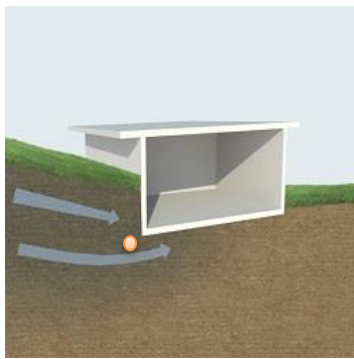

**Waterproof tanking**  
3PT on wall /  
3PTM underslab

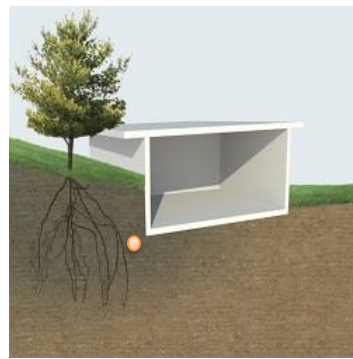

**Waterproof tanking**  
3PG on wall /  
3PTM underslab

Nuraply 3PT system is primarily used to waterproof vertical surfaces. No plants may be located nearby unless Nuraply 3PG (with an anti-root inhibitor inbuilt) is used instead. Throughout this document where 3PT is mentioned it covers 3PT, 3PT-SA or 3PG

Nuraply 3PTM is used for underslab, foundation and blindside wall waterproofing. Laid chip side up it keys into the poured concrete slab.

Any failure or deficiency of inaccessible below ground waterproofing of a structure, can be very difficult and expensive to correct.

Nuraply is a positive (rather than passive) waterproofing system that is watertight immediately upon installation.



---

## **NURAPLY 3P COVERED MEMBRANE INSTALLATION MANUAL**

---

It is common practice to use polythene vapour barriers under slabs. These barriers are not part of the waterproofing system and cannot be sealed to the Nuraply 3PT system to form a complete waterproofing system. As described in BRANZ Bulletin 397, Nuralite does not recommend the mixing of materials.

Nuraply 3P covered membranes are designed for permanent waterproofing. Full integrity and benefit in service will be achieved by close supervision of the system application to ensure correct design and good detailing on site. Care must be taken once the membrane is installed to ensure it is not damaged prior to backfilling or installing the covering system.

## NURAPLY 3P COVERED MEMBRANE INSTALLATION MANUAL

### 3. Nuraply 3P Covered Membrane System Components

#### *Wall Tanking Product Selection*

Substrate		Concrete or Brick
Substrate Comments		Clean, dry and smooth surface required
Adhesive/Primer		
	Nuraflux	Yes
Wall Membranes		
	Nuraply 3PT	Yes
	Nuraply 3PT-SA	Yes
	Nuraply 3PTM (A)	Yes
	Nuraply 3PG (B)	Yes
Drainage layer		
	Nuradrain	Yes
Insulation		
	IKO Enertherm ALU	Yes
Notes		

(A) Use if tanking is exposed to UV or for blindside installations

(B) Use if vegetation is close to the tanking installation to prevent root damage

## NURAPLY 3P COVERED MEMBRANE INSTALLATION MANUAL

---

### *Car Park Product Selection*

Substrate	Concrete
Minimum Finished Fall	Nominally zero (A)
Substrate Comments	
Adhesive/Primer	
Nuraflux	Yes
Membranes	
Nuraply 3PC	Yes
Notes	

A) Back falls are not acceptable and must be corrected. Where areas are found by a site level survey to have negative falls, i.e. will hold water, remedial action should be taken, e.g. localized screed or additional rainwater outlet. To prevent ponding caused by lap build ups around rainwater outlets, these should be recessed or fitted in sumps, where practical.

## NURAPLY 3P COVERED MEMBRANE INSTALLATION MANUAL

### Greenroof Product Selection

Substrate	Plywood (A)	Concrete (A)	Concrete with Tapered Boards or Flat Enertherm (Nuratherm)	Plywood with Enertherm (Nuratherm)	Hibond Metal tray with Enertherm (Nuratherm)
Minimum Finished Fall (excluding gutters) (B)	1:80	1:80	1:80	1:80	1:80
Gutters	1:100	1:100	1:100	1:100	1:100
Substrate Comments	Using minimum 17mm plywood, rafters at 600 centers, nogs at 600 centers.	Option to create required slope with a screed. Wait for concrete and screed to cure.	Nuralite to assist with tapered board layout	Using minimum 17mm plywood, rafters at 600 centers, nogs at 600 centers.	

Due to weight constraints an Engineer must validate the substrate's structural design

#### Adhesive/Primer

Nuraflux	Yes	Yes	Yes	Yes	Yes
----------	-----	-----	-----	-----	-----

#### Vapour Barrier

Nuraply ALU			Yes	Yes	Yes
-------------	--	--	-----	-----	-----

#### Insulation (B)

Enertherm			Yes	Yes	Yes
Tapered Enertherm at 1:60			Yes		

#### Insulation fixing

IKO Fix				Yes	Yes
Nurabond High Foam PU			Yes		

#### Basesheet

Nuraply 3PB	Yes	Yes			
Nuraply 3PB-SA	Yes	Yes	Yes	Yes	Yes

#### Capsheets

Nuraply 3PG	Yes	Yes	Yes	Yes	Yes
-------------	-----	-----	-----	-----	-----

#### Drainage layer

Greendrain (C)	Yes	Yes	Yes	Yes	Yes
----------------	-----	-----	-----	-----	-----

#### Notes

A) On Cold Roofs, no venting of the substrate is allowed through the Green Roof system. Use either a Nuratherm Warm Roof or cross flow ventilation

B) Roofs must have a minimum finished fall of 1:80. This is the fall that is achieved on the roof at the completion of construction. Designers should make allowance for construction tolerances and deflection to ensure the falls are achieved onsite.

C) A layer of heavy duty Polyethylene must be installed as a separation layer before laying out the Greendrain mat

---

## NURAPLY 3P COVERED MEMBRANE INSTALLATION MANUAL

---

### Membrane

#### *Nuraply 3PT Membrane*

Nuraply 3PT is a modified bitumen with a 180gm/m<sup>2</sup> spunbound composite polyester reinforcement, with a thin thermofusible film on both sides of the membrane. (*Labelled: Nuraply 3P F/F 10m*)

#### *Nuraply 3PT-SA Membrane*

A nominally 3mm thick, 15m long x 1.08m wide polymer modified bitumen sheet, first layer waterproofing. Self adhering onto the primed substrate. With heat welded lap joints and a sand upper surface. (*Labelled: IKO Base Stick T/SA 15m*)

#### *Nuraply 3PTM Underslab Membrane*

Nuraply 3PTM reinforced fibre asphalt with a mineral chip face to key into slab. A flexible, tough, waterproofing system applied and joined by welding. Nominal thickness of 3mm.

The chip surface on the Nuraply 3PTM makes the membrane suitable for exposure to UV light. It should be used as the tanking membrane on all surface that is exposed to UV. (*Labelled: IKO gum, IKO GUM 4000*)

#### *Nuraply 3PG Membrane*

Nuraply 3PG is an modified bitumen with a 180gm/m<sup>2</sup> spunbound composite polyester reinforcement, with a thin thermofusible film on one side and sand on the other. Incorporated into the membrane is an inbuilt root inhibitor. (*Labelled: IKO Roofgarden 7.5m*)

#### *Nuraply 3PC*

Nuraply 3PC is nominally 5mm thick, 10m long x 1m wide polymer modified bitumen. Heat fused onto the substrate with heat welded lap joints and talc upper surface. Consists of a 280 g/m<sup>2</sup> impregnated carrier with combination of polyester and glassfleece covered at the bottom side with flexible polymer bitumen.

The finish of the top surface of this membrane, talcum, admits direct application of road asphalt at a temperature of max. 160°C-200°C or mastic asphalt with a temperature rox 250 °C.

The positioning of the carrier close to the upper surface of the membrane ensures a thorough adhesion between membrane and substrate. (*Labelled: IKO Polybridge 5 T/F*)

#### *Nuraply 3B - On Timber or Concrete*

Basesheet under Nuraply 3PG. Nuraply 3PB provides a nominally 3mm thick 10m long x 1m wide polymer modified bitumen sheet. All internal and external corners and vertical to horizontal transitions shall have Nuraply 3PB membrane gusset patches and strips applied before the main membrane application. (*Labelled: Nuraply 3P F/F 10m*)

#### *Nuraply 3PB-SA - On Timber, Concrete or Enertherm PIR panels*

Basesheet under Nuraply 3PG. A nominally 3mm thick, 15m long x 1.08m wide polymer modified bitumen sheet, first layer waterproofing. Self adhering onto Enertherm PIR insulation panels substrate. With heat welded lap joints and a sand upper surface. (*Labelled: IKO Base Stick T/SA 15m*)



---

## **NURAPLY 3P COVERED MEMBRANE INSTALLATION MANUAL**

---

### *Nuraply 3PM - Mineral Chip*

Nuraply 3PM Sheet is nominally 4mm thick, 7.5m long x 1m wide, polymer modified bitumen sheet with a prefinished mineral chip upper surface. For use on all exposed upstands. (*Labelled: IKO Carbon Turbo 7.5m*)

### **Additional Components Supplied by Nuralite**

#### *Nuraflux Primer*

A solvent-based, bituminous primer designed to penetrate concrete or ply surfaces and provide a bondable surface. Supplied in 25ltr metal pails.

#### *Nurapatch*

Two pack high strength finishing & repair plaster

#### *Nuralite Bitumen Fillet*

A triangle of bitumen that may be installed at internal corners instead of building a mortar fillet.

#### *Nuradrain Protection Sheet*

Rot-proof board for use as a protective barrier and drainage medium behind retaining walls.

#### *Greendrain Protection Sheet*

Rot-proof board for use as a protective barrier, water retention and drainage mat beneath Greenroof growing medium.

#### *Nuradrain Self-Adhesive Mechanical Fixing*

A Self-Adhesive mechanical fixing to secure Nuradrain to the substrate.

#### *Termination Bar*

Metal strip predrilled to allow mechanical fixation of the Nuraply 3PT membrane and Nuradrain

#### *Nuraswell*

A controlled hydrophilic swellable gasket that expands in a controlled fashion when exposed to moisture, forming a seal in concrete joints. May be used at the junction of a poured concrete wall and a concrete floor slab.

#### *IKOPro Stickall*

IKOPro Stickall is a dense, all weather, bituminous sealing glue that remains plastic under normal temperatures and adheres well to most building surfaces.

#### *Nuraply ALU*

Roofing membrane with glass fibre reinforcement, topside finished with polyester reinforced aluminium foil and under-side coated with self-adhesive SBS modified bitumen. Applicable as vapour barrier for roofing systems in buildings with high humidity conditions. (*Labelled: IKO Shield PRO ALU/SA 25m*)

#### *Enertherm*

Enertherm is a 100 % CFC, HCFC and HFC-free insulation board with a core in hard polyisocyanurate foam, coated on both sides with a multi-layer gastight aluminium complex. (*Labelled: IKO Enertherm*)

---

## **NURAPLY 3P COVERED MEMBRANE INSTALLATION MANUAL**

---

### *IKOFix*

Polypropylene telescopic sleeves for fixing membrane and insulation. Screws supplied in lengths to suit the installed insulation.

### *Nurabond High foaming PU Adhesive*

A permanent elastic high performance moisture-cured single part polyurethane adhesive with light foaming capacity for bonding bituminous roofing membranes, vapour control layers and rigid insulation boards. For use on various substrates including profiled metal decking, existing bitumen membranes, concrete, timber etc. (*Labelled: IKOPro PU Adhesive*)

### *Nuratrim*

A metal edge that provides a mechanical fixing of the membrane and watercheck. Designed to be installed on roof edges, verges and parapets without a slope.

### *Metal Scuppers & Sumps and Gravel Guards*

Fabricated for use with Nuraply 3P. Available in 80, 100 and 150mm sizing with alternative dimensions available on request.

### *Termination Bar*

20mm x 3mm metal strip predrilled to allow mechanical fixation of the Nuraply 3P membrane.

### *MS Detail liquid flashing*

MS Detail is a solvent-free, coloured, liquid, single-component waterproofing coating on the basis of MS Polymer technology.

### *Nuralite outlets and overflows*

A series of roof outlets which provides a robust means of connecting a roof system to an outlet drain. For use on flat roof applications for either commercial or residential buildings.

### *Nuradeck*

A tough liquid-applied, elastomeric, fibreglass reinforced waterproofing system suitable for detailing terminations and flashings.

### *Nurajacks & Nurapads*

A Tile or Paving support system that is height adjustable and includes a self levelling head to automatically compensate for the deck gradient or any difference in the level of the substrate. Allows the tile or timber deck to be independent of the waterproofing membrane.

### *Nuracoat BG (optional)*

Nuracoat BG forms a durable, highly elastic films that adheres well to most common substrates e.g. Enertherm PIR, Nuraply bitumen membranes, concrete, cementitious products and wood. Nuracoat BG is highly resistant to chlorides and sulphates commonly present in soil.

---

## **NURAPLY 3P COVERED MEMBRANE INSTALLATION MANUAL**

---

### *Lockin' Pocket flashing system*

A pre-fabricated inter-locking flashing system that is easily assembled on-site and filled with fast setting, solvent free, Hurricane Force Universal Sealer. The system becomes waterproof within minutes of application. Lockin' Pocket is designed to seal technically challenging roof penetrations where field flashing may not be practical. When installed and filled with Hurricane Force Universal Sealer, the Lockin' Pocket Inter-Locking Flashing System becomes a long lasting, waterproof, solid mass that can make the most challenging penetrations watertight in minutes.

The Lockin' Pocket system includes:

- Interlocking Corners
- Interlocking straights 150mm, 200mm, 250mm, 300mm
- Fully moulded square pockets 150mm, 200mm
- LPS Sealant
- Hurricane Force Universal Sealer

### **Accessories supplied by Others**

#### *FixAll 220 MS Sealant (Supplied by Holdfast)*

High performance MS sealant

#### *Metal Jubilee Clip*

An adjustable steel band secured with a screw.

#### *HiBond Metal Tray (Dimond)*

A metal tray deck substrate with wide ridges to support the Enertherm sheets.

#### *Heavy Duty Polyethylene*

General purpose heavy weight black polyethylene. 250mu.

#### *Gorilla Fire Rated Expanding Foam (Supplied by Holdfast)*

A one-component, self-expanding, ready to use polyurethane foam. Seals against smoke and gas. Insulates, adheres & waterproofs

Store NURALITE waterproofing systems rolls and accessory materials under conditions that ensure no deterioration or damage. Store in shade or cover in hot sun. Protect liquid components from freezing.

## **4. Health and Safety**

An applicator's wellbeing is paramount.

**Do not enter a worksite, commence work or continue working if:**

1. You have not been adequately trained by your employer
2. You have not been briefed about the workplace hazards by the site manager
3. You do not have proper clothing, footwear, safety & workplace equipment.
4. You witness unsafe practices or you believe the workplace is unsafe.

**Use your commonsense and speak up if anything concerns you.**

A few points of particular relevance to Applicators are:

1. Applicators must wear protective clothing including a hat and suitable footwear. In particular, heat resistant gloves must be worn to reduce the risk of torch flame and heated bitumen coming into contact with skin. Footwear should have soft, non-slip soles.
2. Working with a gas torch is hazardous and requires care both for the Applicator, other associated personnel, and other persons on the work site.
3. Regular checks of all gas equipment to ensure that it is in good working order and safe for use. All personnel who use this equipment should be trained in its proper use and maintenance.
4. As torch-work can create the risk of fires, including smouldering fires, the Applicator must be trained in fire prevention and the proper extinguishing of fires. On every job fire extinguishing equipment must be kept close to the Nuraply 3P installation area and be in good working order.
5. First aid equipment must be provided on site and work personnel trained in first-aid procedures.
6. Tanking work is performed in confined spaces. Before entering a space ensure it is safe to work in and particularly ensure that banks are well formed.

## **5. Project Administration/Supervision**

Many poor jobs are found to result from membranes being laid on top of a badly constructed substrate.

Before commencing laying any Nuraply 3P systems, the installer must be sure that the substrate is ready by receiving a completed Nuraply 3P Substrate Readiness Checksheet from the main contractor (builder). The installer should contact Nuralite in case of any concerns.

Be sure to store the completed forms and supply them to Nuralite when the Materials Defects Warranty is applied for.

Before commencing work, the Applicator must determine:

- That all the building consents, if required, have been issued and the specifications and detailed drawings are workable and suitable for the project
- That there is nothing that will compromise the Applicator's required responsibility under the NZ Building Code or your ability to follow these instructions and thus issue a warranty on your workmanship
- That no existing conditions at the site prevent the Applicator from performing in a professional and safe manner
- That the product to be installed is as per the building consent documents.
- A substrate readiness checklist has been completed by the main contractor (builder) (see section 10) and then a copy attached to the warranty application.

## 6. Nuralite Site Requirements

It is the responsibility of the main contractor (builder) to provide a suitable site and correctly prepared substrate for the applicator. Work should not commence until the site requirements are all met.

### DE-WATERING (Responsibility of Main contractor (builder))

It is important to adequately drain the area where the membrane is being installed. To drain, dig a hole next to the installation area to position the pump. The hole should be deeper than the area to be drained. Use the pump to remove water from the installation area. In large construction situations a full site dewatering system may be required.

Maintain water level at not less than 300mm below the level of the base concrete during the progress of the tanking work and until waterproofing of the walls is complete.

### THE UNDERSLAB SUBSTRATE SHOULD BE:

- Granular fill, sand blinding and compaction to comply with the requirements of NZS 3604.
- Dress off surface of hardfill with a 15mm layer of fine, clean sand rolled to a smooth surface. Alternatively, a screed of site concrete no less than 50mm thick, can be used in place of compacted sand.
- Granular fill in excess of 600mm may require a Geotechnical Engineer to investigate the underlying soil substrate layers for specific design requirements.

### THE WALL SUBSTRATE SHOULD BE:

- Clean, dry and cured. Dewater must be complete.
- All surfaces are clean and free from voids, spalled areas, loose particles, and sharp protrusions. No projections of sharp materials exist that will cause damage to tanking. Check that masonry joints are struck off flush.
- Smooth off the surface so as not to allow water to track behind the membrane. Remove any projections, sharp edges, boxing lines, and nail spikes, wire-brush and remove all debris, leaving the surface dust-free, oil-free and clean, with nothing that could diminish the adhesion of primers. Fill tie holes flush and smooth with NURAPATCH. Grind off steps or sharp protrusions caused by formwork joints.
- All gaps, except expansion joints, between panels or blocks must be filled and flush-pointed, with no bridging points or gaps.
- Form oils or release agents and curing compounds must be completely removed.
- Remove back forms to ensure no vapour pressure develops beneath the membrane.
- Fit a minimum of 20mm mortar or Nuralite Bitumen Fillets to all internal junctions.
- On an external corner, first grind the corner to produce a smooth 25mm radius or chamfer.
- Allow concrete and masonry to cure before applying tanking.

### DRAINAGE (Responsibility of Main contractor (builder))

A drainage system to remove water from foundations must be installed. Ensure drain is protected with geotextile cloth to prevent it clogging with fines, and that it is correctly located below the footing with positive drainage.

The drainage system should be designed to cope effectively with the anticipated volumes of water on the site.

## 7. Installing the Nuraply 3P Covered Membrane system

Apply Nuraply 3P covered systems only in fair weather with air temperature above 5°C.

Before commencing work confirm that a Nuraply 3P Substrate Readiness Checksheet has been completed.

### a) *Underslab Membrane*

Loose lay Nuraply 3PTM as a damp-proof membrane under a concrete slab. The membrane to be laid with mineral chips face up.

Fully heat weld all sheet joints by gas torch. Ensure all joints are well sealed with a minimum lap of 80mm. This is indicated by the presence of a thin bead of melted bitumen at all sheet joints after torching. Ensure the under slab membrane extends 150mm beyond the building perimeter.



Take care when placing reinforcing steel to avoid puncture or damage to the Nuraply 3PTM membrane.

Possibly the most common cause of system failure is damage caused during construction. This often happens at the point where the under slab section of the membrane is left projecting 150mm for later connection to the vertical section and it is not protected. During construction of the structural wall this unprotected section can be perforated by being trodden on, by reinforcing steel, by shuttering braces and pegs or by falling debris.

Ensure the 150mm flap is protected by sandwiching the 150mm flap between two sheets of plywood which are screwed together.

When it is time to install the flap, remove the plywood and bring this flap portion of membrane up and torch to wall base. Install the wall membrane down over the top to form a sound seal.



## **b) Walls And Foundations Membrane**

All surfaces are clean and free from voids, spalled areas, loose particles, and sharp protrusions. Check that masonry joints are struck off flush.



### **PRIMING**

Prime the substrate with NURAFLUX at a rate of 5-6m<sup>2</sup>/tr, ensuring good even coverage.

Allow reasonable time for the primer to become touch dry and fumes to dissipate. Failure to do this may result in adhesion problems or flashover from ignited vapours.

You may have to re-prime substrates if there is a very porous substrate or a delay in installing the membrane which results in the primer losing its tackiness. These delays increase the likelihood of adhesion problems due to contamination.

### **EXPANSION JOINTS**

Expansion joints are required between tilt slabs. Apply a cut 100mm wide reinforcing strip of Nuraply 3PT. Mould the reinforcing strip into the joint so that any flexation pushes inward rather than outward.

### **REINFORCEMENT STRIPS**

Apply a cut 200mm wide reinforcing strip of NURAPLY 3PT over all changes in planes and in risk areas such as the joint between the wall and footing.

### **INSTALLING MEMBRANE**

For Nuraply 3PT, starting at the top of the wall, using the gas torch, burn off the polyethylene and create a small bead of molten bitumen along the front edge of the roll as it is uncoiled down or along the wall.

For Nuraply 3PT-SA, starting at the top of the wall, peel back the polyethylene uncoiled down or along the wall. Use a roller to firmly press the membrane to the wall

When the entire roll is bonded to the substrate seam weld all laps. Ensure a bitumen bleed is evident along the length of the lapjoint.





---

## **NURAPLY 3P COVERED MEMBRANE INSTALLATION MANUAL**

---

Ensure rolls are installed straight and that a minimum 80mm side lap is maintained, and that a minimum 150mm end laps are formed.

It is critical to ensure all laps are fully formed and that the system is fully watertight. Once it is covered, it is often impossible to get back to the membrane to undertake repairs.

Ensure there is no bubbling of the wall membrane. It is important that it is fully bonded to the substrate.

Bring the under-slab membrane up, torching it to the base of the walls. Install the wall membrane over this portion forming the floor-to-wall junction. Ensure a good seal.

### **PILE CAPS**

Clean the top of the pile cap thoroughly and flush smooth with a high strength mortar. Install a Nuralite Bitumen Fillet around the pile cap. Prime the area with Nuraflux ensuring good even coverage. Install a Nuraply 3PT under-flashing by cutting and dressing the under-flashing around the pile cap perimeter and up over the fillet onto the top of the pile cap. Terminate the under-flashing clear of the rebar. In the same way, install the Nuraply 3PT cap-sheet ensuring all laps are well bonded, and that the base-sheet and capsheet membrane cuts are off-set. Ensure all work is fully bonded and a watertight seal is formed.

### **PENETRATIONS**

Cut a star shape pattern in the membrane to form a collar and slip over the metal pipe protrusion. Torch into place and then wrap 150mm wide strip of membrane around the pipe. Torch seal off all edges. Complete detail with a Jubilee clip to provide mechanical termination

### **UNEVEN PENETRATIONS**

Make sure membrane substrate is clear of loose gravel, dirt, granules, or all foreign substances that can affect adhesion. Place Lockin' Pocket in desired location and mark the outside edge for reference. Lockin' Pocket should be placed to assure at least 50mm clearance from the inside of the Lockin' Pocket to the penetration on all sides. Seal base of penetration with LPS sealant to prevent Hurricane Force Universal Sealer from flowing through openings. Apply a liberal bead of LPS to the substrate where Lockin' Pocket will be placed and apply a liberal bead of LPS to the locking joint of the Lockin' Pocket. Set Lockin' Pocket in place and apply equal pressure to assure positive contact with the membrane surface. Fill assembled pocket with Hurricane Force Universal Sealer until completely full.

### **MEMBRANE TERMINATION**

Terminate the membrane using a Nuralite Termination bar and LPS sealant, or terminate into a chase if overflashing.

Use Nuraply 3PTM for tanking any areas exposed to UV or overlay a second layer of Nuraply 3PM in exposed areas.

As sections of tanking are completed, arrange for inspection of the work before covering with protective sheets, walls, or slabs.

---

## **NURAPLY 3P COVERED MEMBRANE INSTALLATION MANUAL**

---

### PROTECTION OF THE INSTALLED WALL MEMBRANES

It is vital to protect the membrane from damage, either from workers on site or during the backfilling operation. Equally important is ensuring the area adjacent to the membrane is free flowing to minimize the buildup of hydrostatic pressure.

The Nuradrain protection board is designed to prevent damage from the construction process generally as well as possible damage from backfill material.

Spot bond the boards in place using IKOPro StickAll bitumen adhesive or use Self-Adhesive Mechanical Fixing.

### **c) Greenroof Membrane**

#### INSTALLING THE ENERTHERM SYSTEM

##### Vapour Barrier

- i. The amount of condensation depends on the temperature in-balance and the humidity of the internal air. Vapour barriers prevent moist air from reaching the dew point and so prevent condensation forming
- ii. Before laying the membrane, prime the substrate with Nuraflux primer.
- iii. When installing the membrane, ensure the Nuraply ALU vapour barrier covers the entire area and wraps up and around the insulation so there is no opportunity for vapour to enter the roof system from below.
- iv. Seal all penetrations carefully and repair any damage to the membrane.
- v. Because no condensation will form within the ceiling cavity there is no need to vent the ceiling when installing a Nuratherm warm roof.

##### Enertherm Boards

- i. Lay the sheets in a brick bond fashion to prevent movement. The sheets can be cut with a knife or saw
- ii. Keep the sheets dry onsite and only install sheets that can be waterproof that day to prevent entrapping moisture.
- iii. It is desirable that no thermal breaks exist in the system.

## NURAPLY 3P COVERED MEMBRANE INSTALLATION MANUAL

---

### Fixing on Timber or Metal Traydeck

- i. IKO Fix fasteners are designed to penetrate the insulation and has the following advantages:

- Reduces thermal bridging
- Is cost effective because it uses shorter screws
- No risk of the screw penetrating the membrane if someone stands on the fixing.

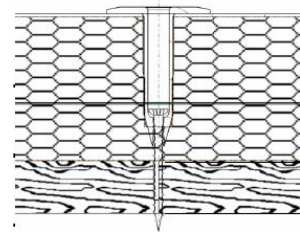

- ii. Secure the sheets with 10 fixing per sheet. The fixings should be inset by 200mm in each corner with at least one in the center.
- iii. If you notice the boards move when walking on them, use additional fixings to ensure the boards are stable and flat.

### Fixing on Concrete

- i. The Nurabond PU Adhesive is cold applied and has been specially developed to allow the safe, rapid partial bonding of roofing components.
- ii. It is moisture curing and tolerant of use in damp conditions. A degree of moisture is required, either in the atmosphere or on the surface, to allow the correct adhesive bond to be achieved. However, all liquid water should be removed from surfaces prior to use.
- iii. Curing time is dependent upon ambient temperature and humidity conditions however, curing will usually occur between 2 to 6 hours. The adhesive will take 24 hours to achieve full bond strength.
- iv. The minimum working temperature is 5°C. At low temperatures, warming the containers in hot water prior to use will improve handling characteristics. (N.B do not boil the product). Maximum working temperature 30°C.
- v. Surfaces to receive adhesive should be stable, clean and free of any liquid water (damp surfaces are acceptable). No priming is required.
- vi. Nurabond High Foaming PU Adhesive is applied straight from the container in strips. The maximum distance between the strips is 25cm. Use the spout on can for pouring lines of adhesive.
- vii. Weight the Enerthem boards once they are laid into the adhesive to ensure a good bond between the two surfaces.

## NURAPLY 3P COVERED MEMBRANE INSTALLATION MANUAL

---

### INSTALLING THE NURAPLY BASELAYER

#### Layout

- i. All surfaces must be checked to ensure they are dry, clean, smooth and free from sharp edges, loose or foreign materials, oil grease or other deleterious material that may affect the adhesion of the membrane or may damage the membrane.
- ii. Plan Nuraply 3PB rolls layout for best drainage. Lay Nuraply 3PB from drainage outlets and gutters, low points and edges, up the roof /deck slopes. Nuraply is usually installed running down the slope to minimize water retention on the roof.
- iii. Be sure to run membrane down the length of the gutter – not across it. There should be no laps within 1m of the outlet.
- iv. Use chalk lines to ensure straight neat lines of the finished membrane.
- v. Double thickness application is a requirement at all internal and external corners, at upstands and turndowns. This will eliminate –
  - (a) The possibility of weakening the Nuraply 3PB when tooling to angles,
  - (b) The possibility of the sheet pulling out from the corner when not mechanically fixed,
  - (c) The double thickness increases the strength to withstand substrate movement and mechanical damage at these points.

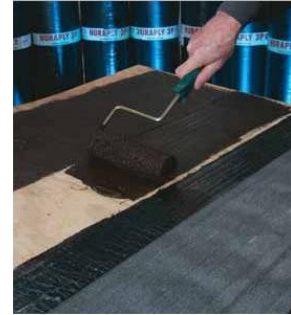

### Adhesion of Nuraply 3PB or Nuraply 3PB-SA Sheet to Timber Substrate

- i. Install detailing (refer to g.) to all drainage outlets gutters and detailing in Nuraply 3PB, before laying the main roof. Ensure outlets are rebated to avoid build-up at outlets and to allow drainage outflow.
- ii. Apply the Nuraflex primer evenly over the area to be waterproofed.
- i. Whilst unrolling the membrane roll use a correct size gas torch to heat the membrane until a bitumen bleed is established (Not required for Nuraply Self-Adhesive membranes). Overlap previous rolls sides 80mm and ends 100mm ensuring all laps face downhill.
- ii. Weld all lap joints carefully using Nuraply 3PG welding techniques, discussed below, and testing all joints progressively.
- iii. Welding and detailing with skill, creates carefully fused laps, with minimal exposed smooth bitumen, and neatly angle tooled joint edges. Stagger the roll lying to avoid four corners meeting in one place.

## **NURAPLY 3P COVERED MEMBRANE INSTALLATION MANUAL**

---

### Adhesion of Nuraply 3PB Sheet to Concrete Substrate

- i. Install detailing (refer to g.) to all drainage outlets gutters and detailing in Nuraply 3PB, before laying the main roof. Ensure outlets are rebated to avoid build-up at outlets and to allow drainage outflow.
- ii. Apply the Nuraflex primer evenly over the area to be waterproofed.
- iii. Whilst unrolling the roll use a correct size gas torch to heat the membrane just enough to completely melt the protective film and start the base bitumen flowing. Overlap previous rolls sides 80mm and ends 100m ensuring all laps face downhill.
- iv. Weld all lap joints perfectly using Nuraply welding techniques, discussed below, and testing all joints progressively.
- v. Welding and detailing with skill, creates perfectly fused laps, with minimal exposed smooth bitumen, and neatly angle tooled joint edges. Stagger the roll lying to avoid four corners meeting in one place.

### Adhesion of Nuraply 3PB-SA Sheet to Enertherm Substrate

- i. Install detailing (refer to g.) to all drainage outlets gutters and detailing in Nuraply 3P-SA, before laying the main roof. Ensure outlets are rebated to avoid build-up at outlets and to allow drainage outflow.
- ii. Whilst unrolling the roll, peel away the protective film and use a roller or stiff broom to press the self-adhesive membrane to the substrate. Overlap previous rolls sides 80mm and ends 100m ensuring all laps face downhill.
- iii. Weld all lap joints perfectly using Nuraply welding techniques, discussed below, and testing all joints progressively.
- iv. Welding and detailing with skill, creates perfectly fused laps, with minimal exposed smooth bitumen, and neatly angle tooled joint edges. Stagger the roll lying to avoid four corners meeting in one place.

### Making the Lap-Joint

- i. To weld lap-joints use the round edged finishing trowel and heat gently. Insert trowel between sheets and lift the edge of the top sheet high enough to allow the torch flame to liquefy both surfaces.
- ii. Both hands must work together, moving back and forth along the sheet a distance of approximately 350mm. When the surfaces are melted, remove trowel and torch flame from between lap-joint.



---

## **NURAPLY 3P COVERED MEMBRANE INSTALLATION MANUAL**

---

- iii. Position hot trowel blade firmly on top of joint approximately 50mm back from the open edge and weld the sheets together with pressure from the hot trowel. Then joggle the top sheet along the back edge of the under sheet to an angle of approximately 45°. Approximately 30mm from the back of the joint is now welded together.
- iv. Re-lift the edge of the upper sheet reheat under it and trowel weld the middle 25mm of the lap with pressure from the trowel. Once again, re-lift the edges of the upper sheet, reheat, and with pressure from the trowel, weld the remainder of the lap to within 5mm of the front edge. Lift the front edge, reduce heat and then apply flame between the sheet edges.
- v. Seal the front with pressure from the trowel, ensuring this time that the trowel follows closely behind the flame. The edge of the trowel is then run along the front edge of the top sheet at about 45° to ensure a good seal.
- vi. Finally, finish the front edge to give a tidy appearance. Each section of jointing (i.e. approx 350mm length) should be completely welded before starting the next section.
- vii. Always keep the trowel hot and scraped free of carbon build-up, to prevent Nuraply surface from dragging. A properly made lap joint should not be capable of being pulled apart at normal temperatures.
- viii. Random test finished and cooled joints with the hot trowel edges, as work progresses.

### Installing Cap Sheet

- i. Before proceeding, ensure the first layer has been completed, is fully bonded to the substrate and that the welded joints are sound.
- ii. If practical floodtest gutters and outlets.
- iii. If there has been an extended period between installing the baselayer and the capsheet then ensure the base layer is clean and dry. It may be advisable to prime the baselayer with Nuraflux primer.
- iv. The laps of the cap sheet must be offset to the laps of the base sheet. Similarly with three or more layered systems.
- v. Weld the upper Capsheets so that they are fully bonded to the immediate under layer by applying heat to the top of the Basesheet and underside of the capsheet as you unroll the capsheet.
- vi. After each two or three rolls are laid. Weld all lap joints perfectly using Nuraply welding techniques, discussed in “5.c Making the Lap-joint”, testing all joints progressively.

### Flood Testing

If possible floodtest vulnerable areas such as gutters and particularly outlets for 24 hours before signing off the job.



## NURAPLY 3P COVERED MEMBRANE INSTALLATION MANUAL

### d) Carpark Deck Membrane

- i. Install detailing to all drainage outlets gutters and detailing in Nuraply 3PC, before laying the main roof. Ensure outlets are rebated to avoid build-up at outlets and to allow drainage outflow.
- ii. Apply the Nuraflux primer (using lambswool roller) to the area that is to be installed with the 3PC membrane, ensuring the correct coverage is used (one litre per five square meters) areas not covered within 24 hours after the curing of the Nuraflux should be reprimed to ensure a completely fully bonded system without any trapped vapour pockets.
- iii. Nuraflux is solvent based so allow curing thoroughly before using gas torches nearby.
- iv. Use chalk lines to ensure straight neat lines to the finished membrane. Position the membrane roll to the chalk line.
- v. Put the Nuraply 3PC onto the welding trolley. Line up the 3PC to run down the falls in the substrate, ensuring a minimum 80mm lap on the sides of the rolls and ends with all laps facing downhill. This is to prevent the lap joints from hindering the water flow.
- vi. Light up the gas torches and heat the membrane until a bleed of membrane is visible at the intersestecion of the membrane and the primed concrete substrate. This process creates a fully bonded membrane without any trapped vapour pockets. Use a heavy or water filled roller to press the membrane down to ensure no pockets of air exist.



- vii. Monitor the edge of the roll to ensure a continuous 5mm bitumen bleed from both sides of the membrane roll. Use pressure roller to push membrane totally flat.



- viii. After every two or three rolls are laid. Check all lap welds for any signs of not enough bitumen bleed. If there is no sign of constant bitumen bleed use a manual Nuraply 3P welding techniques to redo the lapjoint (see section b below) and test all joints progressively.
- ix. Welding and detailing with skill, creates perfectly fused laps, with a 5mm minimal exposed smooth bitumen, and neatly angled joint edges. Stagger the roll lying to avoid four corners meeting in one place.

#### Making the Lap-Joint manually

- i. To weld lap-joints manually use the round edged finishing trowel and heat gently. Insert trowel between sheets and lift the edge of the top sheet high enough to allow the torch flame to liquefy both surfaces.
- ii. Both hands must work together, moving back and forth along the sheet a distance of approximately 350mm. When the surfaces are melted, remove trowel and torch flame from between lap-joint.
- iii. Position hot trowel blade firmly on top of joint approximately 50mm back from the open edge and weld the sheets together with pressure from the hot trowel. Then joggle the top sheet along the back edge of the under sheet to an angle of approximately 45°. Approximately 30mm from the back of the joint is now welded together.
- iv. Re-lift the edge of the upper sheet reheat under it and trowel weld the middle 25mm of the lap with pressure from the trowel. Once again, re-lift the edges of the upper sheet, reheat, and with pressure from the trowel, weld the remainder of the lap to within 5mm of the front edge. Lift the front edge, reduce heat and then apply flame between the sheet edges.





## NURAPLY 3P COVERED MEMBRANE INSTALLATION MANUAL

---

- v. Seal the front with pressure from the trowel, ensuring this time that the trowel follows closely behind the flame. The edge of the trowel is then run along the front edge of the top sheet at about 45° to ensure a good seal.
- vi. Finally, finish the front edge to give a similar appearance to the joggled edge by adjusting the trowel angle and dressing the front edge. Each section of jointing (i.e. approx 350mm length) should be completely welded before starting the next section.
-  vii. Always keep the trowel hot and scraped free of carbon build-up, to prevent Nuraply 3PC surface from dragging. A properly made lap joint should not be capable of being pulled apart at normal temperatures.
- viii. Random test finished and cooled joints with the hot trowel edges, as work progresses.

### 3PM upstands

- i. Apply a 3PB reinforcing strip at the base of the upstands a minimum of 100mm on the horizontal and 100mm to the vertical ensuring a bitumen bleed is present at all lap joints.
- ii. Continue with the horizontal 3PC layer 70mm up the upstands.
- iii. Apply a layer of 3PM as a finishing cap sheet ensuring a horizontal lap joints of 50mm minimum.
- iv. Check all lap joints for a continuous bitumen bleed.

### Flood Testing

If possible floodtest vulnerable areas such as gutters and particularly outlets are for 24 hours before signing off the job.

## 8. Post Membrane Installation

### a) *Drainage behind the wall (by others)*

Subsoil drainage shall be provided to divert groundwater from behind the basement wall to an appropriate outfall beyond the building. The drainage should be able to cope with the anticipated volumes of water likely on site.

- The subsoil drainage system must use a pipe of at least 100 mm diameter, with openings to collect water,
- Have the subsoil pipe at the base of the wall with invert a minimum of 200 mm below floor level and pipe sloped a minimum of 1:200 to the outlet,
- Incorporate a geotextile fabric or other filter material to prevent silting of the pipe,
- Have access for cleaning subsoil pipe, and
- Have, for the height of the buried wall, free draining backfill above the pipe.



In cases where the tanking is of a deep basement where there is the possibility of ground water under pressure, it is wise to incorporate a sump fitted with a float-switched pump to clear water away.

### b) *Greenroof Drainage, Soil Substrate & Plant Installation – (by others)*

Ensure a Membrane Project Sign-off form has been completed by the main contractor (builder) as a sign that the membrane has been correctly installed. The next trades installer will be responsible for damage once the Project Sign-off form has been completed.

The first layer above the waterproofing must always be a heavy duty polyethelene sheet, with edges taped together. This is designed to provide a demarcation with the Nuraply 3PG and will provide an element of protection from trades walking on the membrane.

Depending on the system selected, a roll of drainage mat or plant trays may then be installed on the polyethelene. Set soil or trays back 300mm from the building or upstands to allow complete drainage in case of a rain deluge. Outlets must also be keep clear so they may be regularly inspected.

The soil buildup must comply with specification. Uneven soil buildup must be avoided so that the building structure does not become overloaded in points.

Soil substrate and plants should be selected by an expert in the field to ensure they plants have the best chance of survival.

No aggressive chemicals or solvents to be used where they may affect the membrane system.

**c) Car Park Overlay Installation – (by others)**

Ensure a Membrane Project Sign-off form has been completed by the main contractor (builder) as a sign that the membrane has been correctly installed. The overlay installer will be responsible for damage once the Project Sign-off form has been completed.

The topping design and installation is the responsibility of others and so is not part of this Codemark.

**Asphalt Overlay**

The asphalt overlay should be placed as soon as possible after application of the Nuraply 3PC and prior to any trafficable use. The parties should inspect the applied membrane prior to laying of asphalt to ensure there is no mechanical damage or other isolated moisture related blisters. Rectify any of those issues before the asphalt application commences.

Only asphalt delivery equipment should be permitted on the membrane prior to placement of the asphalt. While flat tracked paving equipment is preferred, either flat tracked or pneumatic tire equipment may be used. Equipment should be inspected prior to use for burrs, stones or sharp projections on tracks which could damage the membrane.

A minimum of 50 mm compacted overlay is recommended. Thicker overlays are recommended for heavy traffic areas, loading zones or fire truck access points. Care should be taken to minimise the possibility of pavement movement on areas with more than a 5% grade. Curved ramps can put particular stress on the paving system as cars are turning under load.

Paving must not be started following rain until the membrane surface is dry.

Take care not to splash bitumen on any surround surfaces, especially the Nuraply 3PM.

Apply a tack coat of Hot Mix primer to the whole membrane area followed by a No.10 or No.15 Hot Mix. The Hot Mix is screeded out and rolled to a minimum compacted thickness of 50 mm. The rolling out procedure is conducted at right angles to the longitudinal lap joints of the already applied membrane sheets. Compaction of the overlay should occur at a minimum asphaltic temperature of 135°C at the deck. Failure to compact the overlay at 135°C or higher may result in premature deterioration of the overlay.



**Concrete Overlay**

A slip layer of heavy duty black polyethene must be installed, with laps taped, so that the concrete cannot bond to the Nuraply 3PC membrane.

Failure to do this can compromise the system as the concrete curing will stress the underlying membrane

An engineer must specify the depth and reinforcing required for the concrete pour. The main contractor (builder) must ensure the polyethene and Nuraply 3PC is undamaged before pouring the concrete.

## **9. Substrate Readiness Checksheets**

Many poor jobs are found to result from membranes being laid on top of a badly constructed substrate.

Before commencing laying any Nuralite systems, the installer must be sure that the substrate is ready by receiving a completed Substrate Readiness Checklist from the main contractor (builder). The installer should contact Nuralite in case of any concerns.

Be sure to store the completed forms and supply them to Nuralite when the Materials Defects Warranty is applied for.

If a project has two or more substrate types, separate checklists must be completed for each substrate and any interface between the substrates is a matter of specific design for each building.

An engineer's certificate is required to establish that deflection from the greenroof load has been considered.

**NURAPLY 3P COVERED MEMBRANE INSTALLATION MANUAL**

---

**Nuraply Tanking Substrate Checklist**

Project Name: \_\_\_\_\_

Form Completed by: \_\_\_\_\_ Company: \_\_\_\_\_

Area ready: \_\_\_\_\_ Applicator: \_\_\_\_\_

**Worksite**

Work area created with sufficient space to perform job safely.

Water level more than 300mm below the level of the base concrete.

**Underslab**

Compacted hardfill up to 600mm in depth installed complying with the requirements of NZS 3604 (2011).

Reinforcing steel has been installed with care to avoid unnecessary puncture or damage.

Protection in place for 150mm overlap of the Nuraply 3PTM

**Concrete Walls**

Structure complies to the New Zealand Building Code and concrete complies with NZS 3101 (2006), blocks complies with NZS 4229 (2013)

Concrete cured with curing membranes removed. Concrete substrate contains less than 5% moisture content.

Cavities and cracks filled with repair mortar, flushed off and cured.

Waterstops installed to construction joints as per specification - located 50mm from rebar.

Concrete surface firm with any soft concrete or laitance removed.

All protrusions removed. Surface free from foreign matter

Mortar or Nuralite bitumen fillets to all upstands and smooth 5mm radius to all external edges

If terminating into a chase, pre-form the chase and ensure it is straight and 20mm deep.

Substrate clean, firm and suitable condition for laying the Nuralite system.

Confirmation that Nuraply 3PT or Nuraply 3PG (if plants will be nearby) to be installed.

---

Signed by main contractor (builder)

Date:

## **NURAPLY 3P COVERED MEMBRANE INSTALLATION MANUAL**

---

### **New Timber Greenroof Substrate Readiness Checksheet** *(to be completed by the main contractor (builder))*

Project Name: \_\_\_\_\_

Form Completed by: \_\_\_\_\_

Company: \_\_\_\_\_

Area ready: \_\_\_\_\_

Applicator \_\_\_\_\_

Engineers certificate provided

Structure complies to the New Zealand Building Code and Timber complies with AS/NZ 2269

H3.2 CCA treated Timber sheets 17mm thick minimum or greater as per engineer certificate.

Timber sheets supported at maximum 600mm centred rafters and nogs for roofs and decks. Unless otherwise specified.

Sheets stagger lay (fully offset) with falls as per plan.

5mm clearances from all abutments, 5mm radius to all exposed edges.

All sheet edges supported, fixed 150mm on edges and 200mm through girth, edges butt-jointed with no gaps except at abutments.

Sheets fixed by gluing and Stainless Steel countersunk screw fixing.

Fillets installed to all internal junctions and neatly fitted.

Mitres neatly formed.

Rainwater outlets and overflow recesses formed to fit outlets rebated into the surface.

Sharp edges and lips removed and cavities filleted. All joints flush.

Plinths formed for any exterior ventilation, solar panels or fixtures.

Substrate dry, clean, firm and suitable condition for laying .

*When substrate is ready complete this form and provide to the Nuralite applicator*

Notes

---

Signed by main contractor (builder)

Date:

**NURAPLY 3P COVERED MEMBRANE INSTALLATION MANUAL**

---

**New Concrete Roof Substrate Readiness Checksheet**  
*(to be completed by the main contractor (builder))*

Project Name: \_\_\_\_\_

Form Completed by: \_\_\_\_\_

Company: \_\_\_\_\_

Area ready: \_\_\_\_\_

Applicator \_\_\_\_\_

Structure complies to the New Zealand Building Code and concrete complies with NZS 3101 (2006)

Concrete cured with curing membranes removed. Concrete substrate contains less than 5% moisture content.

Surface smooth and clean with falls as per plan.

Cavities and cracks filled with repair mortar, flushed off and cured.

Concrete surface firm with any soft concrete or laitance removed.

Excessive ponding areas removed.

Roof drains and overflow recesses formed to fit rebated outlets.

Mortar or Nuralite Bitumen fillets to all upstands and smooth 5mm radius to all external edges

If terminating into a chase, pre-form the chase and ensure it's straight and 20mm deep.

Plinths formed for any exterior ventilation, solar panels or fixtures.

Construction joints incorporated in slab as per designer's specification.

Substrate clean, firm and suitable condition for laying the Nuralite systems.

*When substrate ready complete this form and provide to the Nuralite applicator*

Notes

---

Signed by main contractor (builder)

Date:

**NURAPLY 3P COVERED MEMBRANE INSTALLATION MANUAL**

---

**New ENERTHERM Roof Substrate Readiness Checksheet**  
*(to be completed by the Main contractor (builder) and Applicator)*

Project Name: \_\_\_\_\_

Form Completed by: \_\_\_\_\_

Company: \_\_\_\_\_

Area ready: \_\_\_\_\_

Applicator \_\_\_\_\_

Engineers certificate provided

Structure complies to the New Zealand Building Code

Sheets stagger lay (fully offset).

Confirm the substrate slope complies with plans.

Rainwater outlets and overflow recesses formed to fit outlets rebated into the surface.

Ensure only approved accessories to be used for drainage and venting.

Review penetrations to minimize number and complexity.

Any gaps in the insulation filled to prevent thermal bridging.

Material fastened with the correct quantity of IKOfix Telescopic Fixing Plates and Fixing Screws.

Edges of insulation supported by metal sheet ridges

Plinths formed for any exterior ventilation, solar panels or fixtures.

Substrate clean, firm and suitable condition for laying the Nuralite systems.

*When substrate ready complete this form and provide to the Nuralite applicator*

Notes

---

Signed by main contractor (builder)

Date:

Signed by applicator \_\_\_\_\_

Date: \_\_\_\_\_



**NURAPLY 3P COVERED MEMBRANE INSTALLATION MANUAL**

---

**10. Installed Product Checksheets**

Tanking Systems

Project Name: \_\_\_\_\_

Form Completed by: \_\_\_\_\_ Company: \_\_\_\_\_

Area ready: \_\_\_\_\_ Applicator: \_\_\_\_\_

- Concrete Substrate checklist completed before work commenced.
- Any movement joints installed to approved specification/detail.
- Mortar or Bitumen fillets fitted to all internal junctions and corners chamfered at a 45° radius.
- All corners and upstands incorporate reinforcing or underflashing
- Under-slab membrane extends beyond footing and carefully protected until vertical membrane installed.
- Side laps 80mm and end laps 150mm fully torched and seamed. Bleed visible on all joints.
- All penetrations installed to specification including under/over flashings.
- Junction of the floor and wall membranes installed to specification fully bonded and watertight.
- All non-standard details installed as per pre-approved specification (attach approved drawings).
- Any membrane punctures or mechanical damage to membrane repaired to specification.
- Membrane termination completed to approved detail.
- Specified drainage system installed below footing as per specification.
- Nuradrain Membrane protection boards installed correctly.
- Membrane fully adhered to substrate with no bridging, bubbling, or delaminating.
- Overall installation free of wrinkles, bubbles, creases and splits.

---

Signed by Applicator

Date:

## NURAPLY 3P COVERED MEMBRANE INSTALLATION MANUAL

---

### Roofing Systems

*(to be completed by the Main contractor (builder) and Applicator)*

Project Name: \_\_\_\_\_  
 Builder Firm: \_\_\_\_\_  
 Applicator Firm: \_\_\_\_\_  
 Area covered by QC Sheet \_\_\_\_\_

Roofing membrane installation item	Comply Y/N/Na	Comments
Substrate readiness form completed		
Underflashings installed to all corners and upstands (pay attention to parapets, gutters, junctions)		
Gutters correctly and neatly installed, particularly the internal corners		
Roof drains & overflows installed to specification and watertight		
Membrane adequately adhered to substrate with no evidence of bubbles or lifting. Correct quantities of primer or adhesive used as per specification.		
Cap sheet and basesheet fully bonded together, no areas of delamination.		
Cap sheet side laps 80mm and end laps 100mm fully welded and tidily seamed off.		
No sign of overheating/excessive bitumen bleed from laps (over 2-3mm).		
Cap sheet and base sheet laps offset satisfactorily. No three layer lap build-ups		
Overall installation free of wrinkles, creases and splits		
Nuraply 3PM installed where membrane is exposed to UV		
All penetration details completed to specification including under/overflashing		
Standard details used throughout including at upstands, parapets, construction joints		
All non standard details installed as per pre-approved specifications (attach approved drawing)		
Gutters and outlets have been floodtested		
Any damage to cap sheet repaired to specification.		

Note: Where an element identified in the above checklist is not applicable, please record N/A in the comply column.



**NURAPLY 3P COVERED MEMBRANE INSTALLATION MANUAL**

---

**Project Sign-off Form cont.**

Remedial action required:

---

---

---

---

---

---

---

---

---

Note of damaged areas repaired:

---

---

---

---

---

---

---

---

---

Signed Main contractor (builder) \_\_\_\_\_

Date: \_\_\_\_\_

Signed Applicator \_\_\_\_\_

Date: \_\_\_\_\_



## NURAPLY 3P COVERED MEMBRANE INSTALLATION MANUAL

---

### 11. Data Sheets

---

#### NURAFLUX PRIMER QD TECHNICAL DATA SHEET

---

##### DESCRIPTION AND AREAS OF USE

Nuraflux Primer is a bitumen based adhesive solvent solution which is specifically formulated to provide excellent adhesion for Nuralite Waterproofing Membranes under many kinds of surface conditions. Nuraflux Primer is an integral part of the Nuralite Waterproofing System and sufficient primer must be used on dry surfaces to condition them to be dust free so that the substrate is suitable for the application of Nuralite Waterproofing Membranes.

Used to prime all structural concrete, masonry, or wood surfaces on which waterproofing membranes will be used.

Designed to be used on applications down to  $-4^{\circ}\text{C}$ .

May be used on horizontal surfaces, but remains tacky, and precautions must be used in this application to prevent contamination of the Primer surface prior to installation of the membrane.

May be used on all concrete block and brick wall conditions.

##### APPLICATION

Nuraflux Primer may be applied with roller, brush or spray. A roller with a heavy nap should be used to carry sufficient material to the area being primed.

Apply all Nuraflux Primer to a clean, dry, dust free and frost free surface at a coverage of approximately 5 sqm/litre. The primer should be spread sufficiently to avoid areas of excess material. Areas of excess material will lengthen the drying time on the application of the primer.

Nuraflux Primer will dry in a minimum of one hour - may dry quicker due to drying conditions, such as wind and warmth.

This product is black in colour and will remain tacky when dry.

The application of primer should be limited to what can be covered with waterproofing membrane in one working day. Any areas not covered with membrane during the day must be reprimed - be sure to cover all open containers when not applying primer, as the primer is volatile.

##### SAFETY, STORAGE & HANDLING INFORMATION

Nuraflux Primer vapours are flammable. User should review Safety Data Sheet (SDS) for this product and follow safety instructions listed therein.

##### TRANSPORT CLASSIFICATION

IMDG Class 3.1

UN No. 1294

**NURAPLY ALU VAPOUR BARRIER**

*IKO shield PLUS ALU/SA*  
**TECHNICAL DATA SHEET**

**DESCRIPTION AND AREAS OF USE**

Roofing membrane with glass fibre reinforcement, topside finished with polyester reinforced aluminium foil and under-side coated with self-adhesive SBS modified bitumen.

The combination of glass fibre reinforcement and aluminium finish layers ensures a dimension-stable, accessible roofing membrane, which facilitates stepping on metal deck during operation.

- The bottom side is coated with self-adhesive, SBS modified bitumen, which guarantees an immediate and high adhesion strength to the substrate surface.
- The top is finished with a polyester reinforced aluminium foil.
- The bottom side is finished with a removable silicon foil.

**APPLICATION**

Self-adhesive vapour barrier on metal deck, accessible during operation.

Also as vapour barrier on fully substrate substructures, if it is dry, dust and fat free.

Nuraply Aluminium Vapour Barrier is applicable as vapour barrier for roofing systems in buildings with high humidity conditions (Inner climate: class IV).

**COMPOSITION**

Type of bitumen: Elastomeric  
 Upper surface finish: ALU  
 Inlay: Glass fibre threads  
 Lower surface finish: Self-adhesive bitumen with anti-stick film

**TECHNICAL CHARACTERISTICS (EN 13707)**

Tensile strength L (EN 12311-1 MDV N/50 MM ± 20%)	800	
Tensile strength T (EN 12311-1 MDV N/50 MM ± 20%)	700	
Elongation L (EN 12311-1 MDV % ± 15% abs.)		NPD
Elongation B (EN 12311-1 MDV % ± 15% abs.)		NPD
Nail tear resistance (EN 12310-1 MDV N Only MF)	≥ 200	
Flexibility at low temperature (EN 1109 MLV °C Surface/Bottom)	≤ -20	
Flow temperature (EN 1110)	NPD	
Shear resistance (EN 12317-1 MDV N/50 mm)		NPD
Dimensional stability (EN 1107-1 MLV)		NPD
Fire resistance		NPD
Vapour diffusion resistance (µd)		≥ 1500 m
Root resistance (EN 13948)	-	

**DIMENSIONS**

## **NURAPLY 3P COVERED MEMBRANE INSTALLATION MANUAL**

---

- Thickness: 0.6 mm
- Length: 25 m
- Width: 1,08 m
- Weight: ± 20 kg
- Packaging: 30 rolls per pallet

### **APPLICATION**

Nuraply Aluminium Vapour Barrier is applied as a vapour barrier in buildings with inner climates till class IV. The substrate should be smooth, dry, clean, fat- and dust free. All substrates, with exception of pre-coated metal deck, needs to be coated with bitumen primer IKOpro SA Primer (Nuraflux QD). In case of application on metal deck the membrane shall be placed parallel on to the corrugations, as to position the side laps supported on the metal deck, and have the ability to rightly pressure it.

The first membrane is unrolled and lined out and rolled up again till approximately half the length of the strip. The remove-able silicon foil should be cut in cross direction and pulled up in one time while unrolling the membrane. This way, the self-adhesive underside will get in direct contact with the substrate and stick immediately. The same procedure should be repeated for the other end of the roll. The next membrane Nuraply Aluminium Vapour Barrier is applied in the same way with a side lap of 8 cm and an end lap of minimum 10 cm. Overlaps are to be pressured with a medium hard pressure roller.

The isolation is applied by bonding with IKOpro PU-Roof Adhesive or mechanically fixing with thermal break flanges and fasteners direct on to the aluminium facing of the Nuraply Aluminium Vapour Barrier.

Insulation types admitted: Mineral wool, EPS without facing, glass fibre faced PUR, PIR and PF (NOT: with talc/sand finished bituminized facing at the underside).

Temperature in application  $\geq 10^{\circ}$  C.

In case of application during colder periods the material should be stored at least 12 hours before application in an ambient temperature of  $\geq 10^{\circ}$  C.

Attention: Finish the roofing system every working day until at least 1 watertight layer on the insulation material in order to protect the aluminium foil of the Nuraply Aluminium Vapour Barrier against thermal shocks.

### **SAFETY, STORAGE & HANDLING INFORMATION**

Do not pile pallets

Store indoors, preferably in dark room; avoid direct sunlight

Apply as quickly as possible after production

Pot-life: depending on circumstances: ideally in dark room at 10 to 20°C, maximum 6 months.

ATAB herewith declares that the following product is in conformity with the provisions of the following EC Directive(s) when installed in accordance with the installation instructions contained in the product documentation:

89/106/EEC Construction Products Directive

EN 13707: Flexible sheets for waterproofing-Reinforced bitumen sheets for roof waterproofing

**NURAPLY 3PB**  
*Nuraply 3P 10m*  
**TECHNICAL DATA SHEET**

---

**DESCRIPTION AND AREAS OF USE**

Waterproofing membrane consisting of straight run bitumen heavily modified with polymers (APP = Atactic Polypropylene) and reinforced with a non-woven polyester.

**FINISHING**

- Top surface a smooth thermofusible film
- Underside finished with a smooth thermofusible film

**APPLICATIONS**

- Underlay in multi-layer waterproofing system

**COMPOSITION**

- Reinforcement: non-woven polyester 180 g/m<sup>2</sup>
- Coating mass: plastomer bitumen, consisting of  $\pm 70$  % bitumen and  $\pm 30$  % atactic polypropylene (APP).

**TECHNICAL SPECIFICATIONS** (average values)

- Tensile strength (U.E.A.t.c.)
  - longitudinal: 600 N
  - transversal: 550 N
- Elongation at break (U.E.A.t.c.)
  - longitudinal: 40 %
  - transversal: 40 %
- Resistance to heat (U.E.A.t.c.): > 140°C
- Low temperature flexibility (U.E.A.t.c.): -5°C
- Dimensional stability:  $\leq \pm 0,5\%$
- Tear resistance (U.E.A.t.c.)
  - longitudinal: 160 N
  - transversal: 160 N





## **NURAPLY 3P COVERED MEMBRANE INSTALLATION MANUAL**

---

### **DIMENSIONS**

- Thickness : 3 mm
- Length : 10 m
- Width : 1 m
- Surface : 10 m<sup>2</sup>
- Average weight : 41 kg

### **SAFETY, STORAGE & HANDLING INFORMATION**

- Do not pile pallets
- Store indoors

### **TRANSPORT CLASSIFICATION**

N/A

**NURAPLY 3PB-SA**

*IKO base, STICK T/SA*

**TECHNICAL DATA SHEET**

---

**DESCRIPTION AND AREAS OF USE**

Roofing membrane with polyester fibre reinforcement for use on areas requiring quality waterproofing without the use of naked flames.

- The polyester reinforcement has high mechanical strength.
- The bottom side is coated with self-adhesive, SBS modified bitumen, which guarantees an immediate and high adhesion strength to the substrate.
- The topside is finished with quartz mineral and a removable silicon foil of 80 mm on the side lap area, which guarantees a fast and secure sealing.
- The bottom side is finished with a removable silicon foil.

**COMPOSITION**

- Reinforcement: polyester fibre, 150 g/m<sup>2</sup>.
- Bitumen coating mass:
  - Topside: flexible bitumen.
  - Bottom side: self-adhesive SBS modified bitumen.

**TECHNICAL SPECIFICATIONS (average values)**

- Tensile strength: (UEAtc)
  - Longitudinal : 700 N
  - Transversal : 500 N
- Elongation at break: (UEAtc)
  - Longitudinal : 35 %
  - Transversal : 35 %
- Low temperature flexibility self-adhering coating : -25°C

**DIMENSIONS**

- Thickness: ± 2.5 mm
- Length: 15 m
- Width: 1.08 m
- Weight: ± 44.5 kg

**APPLICATION**

The substrate should be smooth, dry, clean, fat- and dust free.

All non-insulated substrates, with exception of pre-coated metal deck, needs to be coated with Nuraflex QD bitumen primer. In case of application on metal deck the membrane shall be placed parallel on to the corrugations, as to position the side laps supported on the metal deck, and have the ability to rightly pressure it.



## **NURAPLY 3P COVERED MEMBRANE INSTALLATION MANUAL**

---

The first membrane is unrolled and lined out and rolled up again till approximately half the length of the membrane. The removable silicon foil should be cut in cross direction and pulled up in one time while unrolling the membrane. This way, the self-adhesive underside will get in direct contact with the substrate and stick immediately.

The same procedure should be repeated for the other end of the roll.

The next membrane Nuraply 3PB–SA is applied in the same way with a side lap of 80 mm. Before unrolling it definitively, the silicon foil on the welding strip of the first membrane shall be removed.

Pressure shall be exerted with a medium hard pressure roller. The end laps should be sealed over a width of at least 100 mm with a smooth flame or hot air gun.

In multi layer roofing systems the top layer of Nuraply 3PM torched-applied onto the Nuraply 3PB–SA.

Temperature in application  $\geq 10^{\circ}$  C.

In case of application during colder periods the material should be stored at least 12 hours before application in an ambient temperature of  $\geq 10^{\circ}$  C.

### **SAFETY, STORAGE & HANDLING INFORMATION**

- Do not pile pallets
- Store indoors, preferably in dark room; avoid direct sunlight
- Apply as quickly as possible after production

### **TRANSPORT CLASSIFICATION**

N/A

**NURAPLY 3PG**

*IKO RoofGarden 7.5m*

**TECHNICAL DATA SHEET**

---

**DESCRIPTION AND AREAS OF USE**

Waterproofing root-resistant membrane, consisting of a non-woven polyester reinforcement, coated with plastomer bitumen. Root resistant top layer for waterproofing systems under green roofs with selected plants or in areas where there is the risk of membrane attack from plant roots.

**FINISHING**

- Top finished with sand
- Underside with a thermofusible film

**APPLICATION**

Lay the second Nuraply 3PG layer by heat fusing over the cleaned repaired and NURAFLEX primed (if necessary) surface of the first layer. Joints in the second layer must not correspond with joints in the first layer. Second layer joints to be welded lap-joints, minimum 80mm wide down roll edges and minimum 150mm wide across roll ends, to the Nuraply 3PG supplier's requirements. Roll junctions must be staggered to avoid 4 layer lap-weld build-up of Nuraply 3P at corners. Ensure unobstructed drainage flow at outlets.

**COMPOSITION**

- carrier: non-woven polyester 180 g/m<sup>2</sup>
- plastomer bitumen, consisting of + 70% bitumen and + 30 % atactic polypropylene (APP), with addition of a root-rejecting element.

**TECHNICAL SPECIFICATIONS (average values)**

- Tensile strength: (UEAtc)
  - longitudinal: 700 N
  - transversal: 450 N
- Elongation at break (UEAtc)
  - longitudinal: 30 %
  - transversal: 40 %
- Low temperature flexibility: -8°C
- Heat resistance (EN 1110): 140 °C
- Dimensional stability (EN 1107-1): < 0,4%
- 4 year period FLL German root-test accomplished



## **NURAPLY 3P COVERED MEMBRANE INSTALLATION MANUAL**

---

### **DIMENSIONS**

- |             |           |
|-------------|-----------|
| - Thickness | : 4 mm    |
| - Length    | : 7.5 m   |
| - Width     | : 1 m     |
| - Weight    | : 36.1 kg |

### **SAFETY, STORAGE & HANDLING INFORMATION**

- Do not pile pallets and keep rolls upright
- Store indoors

### **TRANSPORT CLASSIFICATION**

N/A

**NURAPLY 3PT**  
*Nuraply 3P 10m*  
**TECHNICAL DATA SHEET**

---

**DESCRIPTION AND AREAS OF USE**

Waterproofing membrane consisting of straight run bitumen heavily modified with polymers (APP = Atactic Polypropylene) and reinforced with a non-woven polyester.

**FINISHING**

- Top surfaced finished with a smooth thermofusible film
- Underside finished with a smooth thermofusible film

**APPLICATIONS**

- waterproofing of underground walls

**COMPOSITION**

- Reinforcement : non-woven polyester 180 g/m<sup>2</sup>
- Coating mass : plastomer bitumen, consisting of  $\pm 70$  % bitumen and  $\pm 30$ % atactic polypropylene (APP).

**TECHNICAL SPECIFICATIONS** (average values)

- Tensile strength (U.E.A.t.c.)
  - longitudinal : 600 N
  - transversal : 550 N
- Elongation at break (U.E.A.t.c.)
  - longitudinal : 40 %
  - transversal : 40 %
- Resistance to heat (U.E.A.t.c.) : > 140°C
- Low temperature flexibility (U.E.A.t.c.) : -5°C
- Dimensional stability :  $\leq \square 0,5\%$
- Tear resistance (U.E.A.t.c.)
  - longitudinal : 160 N
  - transversal : 160 N



## **NURAPLY 3P COVERED MEMBRANE INSTALLATION MANUAL**

---

### **DIMENSIONS**

- Thickness : 3 mm
- Length : 10 m
- Width : 1 m
- Surface : 10 m<sup>2</sup>
- Average weight : 41 kg

### **SAFETY, STORAGE & HANDLING INFORMATION**

- Do not pile pallets
- Store indoors

### **TRANSPORT CLASSIFICATION**

N/A



**NURAPLY 3PTM**  
**TECHNICAL DATA SHEET**

---

**DESCRIPTION AND AREAS OF USE**

Waterproofing membrane consisting of straight run bitumen heavily modified with polymers (APP = Atactic Polypropylene) and reinforced with a non-woven polyester.

**FINISHING**

- Top surfaced finished with a mechanically rolled slate layer offering excellent bonding with PP film on the 8 cm overlap.
- Underside finished with a thermofusible film

**APPLICATIONS**

- Waterproofing underneath poured floor slabs

**COMPOSITION**

- Reinforcement : non-woven polyester
- Coating mass : plastomer bitumen, consisting of  $\pm 70$  % bitumen and  $\pm 30$  % atactic polypropylene (APP).

**TECHNICAL SPECIFICATIONS** (average values)

- Tensile strength (U.E.A.t.c.)
  - longitudinal : 600 N
  - transversal : 550 N
- Elongation at break (U.E.A.t.c.)
  - longitudinal : 40 %
  - transversal : 40 %
- Resistance to heat (U.E.A.t.c.) :  $> 140^{\circ}\text{C}$
- Low temperature flexibility (U.E.A.t.c.) :  $-5^{\circ}\text{C}$
- Dimensional stability :  $< 0,5\%$
- Tear resistance (U.E.A.t.c.)
  - longitudinal : 160 N
  - transversal : 160 N



## **NURAPLY 3P COVERED MEMBRANE INSTALLATION MANUAL**

---

### **DIMENSIONS**

- Thickness : 3 mm
- Length : 10 m
- Width : 1 m
- Surface : 10 m<sup>2</sup>
- Average weight : 41 kg

### **SAFETY, STORAGE & HANDLING INFORMATION**

- Do not pile pallets
- Store indoors

### **TRANSPORT CLASSIFICATION**

N/A

**NURAPLY 3PM**  
*IKO CARBON (Charcoal)*  
**TECHNICAL DATA SHEET**

---

**DESCRIPTION AND AREAS OF USE**

Waterproofing membrane consisting of non-woven polyester coated with plastomer bitumen. With slate layer in either Charcoal, Slate, White, Red or Green.

**FINISHING**

- Top surfaced finished with a mechanically rolled slate layer (colour red) offering excellent bonding with PP film on the 8 cm overlap.
- Underside finished with a thermofusible film

**APPLICATION**

- Cap sheet in multi layer waterproofing system

**COMPOSITION**

- Reinforcement: non-woven polyester
- Coating mass: plastomer bitumen, consisting of  $\pm 70$  % bitumen and  $\pm 30$  % atactic polypro-pylene (APP).

**TECHNICAL SPECIFICATIONS** (average values)

- Tensile strength (EN 12311-1)
  - longitudinal: 650 N
  - transversal: 500 N
- Elongation at break (EN 12311-1)
  - longitudinal : 40 %
  - transversal : 40 %
- Resistance to heat (EN 1110):  $> 140^{\circ}\text{C}$
- Low temperature flexibility (EN 1109):  $-8^{\circ}\text{C}$
- Dimensional stability (EN 1107-1):  $\leq 0,5$  %



## **NURAPLY 3P COVERED MEMBRANE INSTALLATION MANUAL**

---

### **DIMENSIONS**

- Thickness : 4 mm
- Length :7.5 m
- Width :1 m
- Surface :7.5 m<sup>2</sup>
- Average weight :43 kg
- Colour :Charcoal, Slate, White, Red or Green

### **FIXING**

Torching method with asphalt burner.

### **SAFETY, STORAGE & HANDLING INFORMATION**

- Do not pile pallets
- Store indoors

### **TRANSPORT CLASSIFICATION**

N/A

---

**NURAPATCH**  
**TECHNICAL DATA SHEET**

---

**DESCRIPTION**

A highly polymer modified, high specification cement render that features strong adhesion and tensile strength development combined with a rapid yet practical through-cure in thicker render sections, with outstanding cured strength, resilience and low shrinkage. The polymer modification used is pure acrylic and not PVA or cellulosic as is common with simpler single pack materials, with resultant far improved alkaline durability, resilience and long-term cracking resistance.

A particular benefit has been careful attention to application mix rheology to give excellent trowel “feel” and build capability allowing ready attainment of specification thickness with reduced application effort. This product can be applied from a feather edge to 20mm thickness and work can often then be completed in a single application, with major labour cost savings achieved.

Major areas of use include finishing and fairing of concrete repair work, flushing of blockwork, and plaster render repairs.

- Water based for ease of use and cleanup.
- Simple, controlled mix on site combining a pre-measured bottle liquid and bagged solids blend. Mix working time “pot-life” – 1 hour plus.
- Ease of trowelling and single pass build capability from feather edge to 20mm.
- Virtually no cure shrinkage, allowing ready attainment of specification thickness and forming of details and corners in a single application.
- Labour saving, and extremely cost effective.
- Low temperatures cure, down to 0°C. Fast through cure minimises weather delays and ensures timely job completion.

## **NURAPLY 3P COVERED MEMBRANE INSTALLATION MANUAL**

---

### TYPICAL PROPERTIES

Specific Gravity (Mix Packaging)	30kg pack, combining 5 litre emulsion bottle and 25 kg bagged powder blend
Shelf life (Unopened)	Minimum 12 months
Working time/"pot-life"	Minimum 1 hour @ 25° C.
Building and usage	For fairing work, between a feather edge and 20mm
Appearance	Highly thixotropic wet mix, low gloss grey mass when cured.  Non-flammable. Wet material is alkaline - Avoid eye and skin contact.

### APPLICATION

Apply to clean surfaces free of loose or friable material. Ideally concrete surface to be patched, should be damp, (but not wet), rather than totally dry to avoid undue suction and cracking. Alternatively, the emulsion component may be "slurred" with an equal amount of Portland cement and this mix used as a thin priming coat. Avoid application in direct sun or in hot windy conditions where this is unavoidable, then keep the new plaster dampened by mist water spray during the first day of cure. This material is cement based and will show efflorescence but because of the high polymer content this is "fixed" and providing a good quality acrylic sealer is used, may be overcoated at three days after application.

Stir or shake the liquid bottle and decant contents into an appropriate mixing container, for example a clean 20 litre pail.

- Add a full bag of the powder blend, slowly, while stirring continuously with a heavy duty drill to avoid lumping. A 30kg packaged unit will yield about 14 litres of mixed material. When all powder has been added continue to mix briefly to a uniform consistency.
- The mixed material has a usable working life in excess of 1 hour.
- If the material should begin to set up earlier, it may be readily re-stirred to return consistency, otherwise do not add water and attempt to use material that will not restir.

---

**NURASWELL**  
**TECHNICAL DATA SHEET**

---

**Application Fields**

Nuraswell is a water swellable waterstop used for waterproofing of construction joints. Typical application fields besides others are as follows:

- Waterproofing of construction joints between different concrete pours
- Waterproofing of saw cut joints
- Waterproofing of pipe penetrations
- Waterproofing of the wall-slab joint

**Properties**

Nuraswell is a waterstop that swells under contact with water. It is applied on the previous concrete pour into the centre of the construction or expansion joint.

Nuraswell is nailed to the concrete.

- 1000% swelling capacity, fully reversible for an unlimited number of cycles
- Dimensionally stable, no wash out, like with Bentonite waterstops
- Retarded swelling, volume increase starts several hours after water contact
- Swelling pressure of >5 bar, extreme resistance against hydrostatic pressure
- Resists 50m water pressure acc. To EN12390-8

**Application**

**1. Substrate Preparation**

Nuraswell is suitable for reinforced joints in concrete bodies.

Remove separating and bond breaking substances from first the concrete section (for example – foundation or slab). Surfaces should be open porous and load bearing. Minimal strength requirement is 15Mpa. Patch larger surface defects with Nurapatch.

**2. Processing**

Due to its enormous swelling pressure Nuraswell must be installed a minimum of 50mm from each edge. **NO NOT** use Nuraswell on concrete walls of less than 120mm in cross section or on concrete block construction.

Fix with nails: Nuraswell can be nailed to the first concrete section. Shoot nails at 150mm spacings through the Nuraswell into the concrete.

Cut overlaps, crossings or terminations of the waterstop in a 45° angle and connect without a gap. Hollow areas of more than 4mm may reduce water tightness significantly.

Plastic pipes can only be treated with Nuraswell up to DN 50 with cold water and up to DN 25 for more than 30°C water temperature. Due to the high swelling pressure plastic pipes may collapse under load. Larger diameters are only permitted with metal pipes.



## NURAPLY 3P COVERED MEMBRANE INSTALLATION MANUAL

---

### 3. Curing

Nuraswell does not require curing. Avoid standing water on the waterstop as this may result in premature swelling of the material. Because of the retarded swelling a short term contact with rain water is a problem.

### Estimating

The required amount is calculated with the planned length of the joint waterproofing.

### Cleaning

Nuraswell does not cause any dirt. Dirty material can be cleaned with a moist cloth. **DO NOT** install material that has already swollen. Wait until the material has completely dried and achieved its original dimensions.

### Technical Specifications

- Colour: Blue
- Dimensions: 5 x 25mm
- Weight: 0.12kg/m
- Substrate temperature: 5 - 35°C
- Water impermeability acc. EN12390-8:
  - Positive side: 5 bar
- Water absorption: 1.2kg/m
- Maximum swelling
  - Potable water 1060%
  - Sea water 750%
  - Saline water 580%

### Packaging

Nuraswell is supplied in rolls of 50m. 4 rolls are packaged in a box (approx. 24kg).

### Storage

Nuraswell can be stored in unopened original packs for 5 years at 5 - 35°C in a dry storage place protected against sunlight.

### Safety

Please observe the actual valid material safety data sheet and follow the described safety measures for handling of the product.

### Transport Classification

N/A



## NURAPLY 3P COVERED MEMBRANE INSTALLATION MANUAL

---

### LOCKIN POCKET TECHNICAL DATA SHEET

---

#### DESCRIPTION

Nuralite's Lockin' Pocket filler is a fast setting, solvent free, multi-use universal sealer that becomes waterproof within minutes of application. Lockin' Pocket is a two-component product that cures via a chemical crosslinking mechanism. Unlike one-part moisture cure sealants, Lockin' Pocket filler will cure consistently and quickly throughout, rather than simply skinning over and remaining tacky on the inside. The enhanced formulation of Lockin' Pocket filler delivers a tough, strong, cured material that withstands the most extreme roof-top conditions. Under severe tensile and shear forces typically experienced on commercial roof installation, Lockin' Pocket provides long-term robust performance.

With a quick tack-free and cure time, Lockin' Pocket provides peace of mind that the roof penetration is fully cured and sealed literally within minutes of filling the pocket. Precision in-line mixing during dispensing starts the curing process immediately and the reactive/curing process is consistent across a wide temperature range even in humid conditions

Lockin' Pocket offers very aggressive bonding properties to a wide-range of substrates including steel, galvanized metal, copper and PVC. The aggressive bonding properties reduce the risk of delaminating from these demanding substrates even under fluctuating thermal and environmental changes experienced on the typical commercial roof.

#### APPLICATION

1. With a utility knife, remove the molded tips at the groove from the mixing head.
2. Attach a mixing nozzle to the threaded mixing head.
3. Place the cartridge into the appropriate applicator.
4. **IMPORTANT!** Dispense an initial amount of Lockin' Pocket filler approx. 60mls into a waste container to ensure a proper mix, then discard.
5. Apply Lockin' Pocket filler directly to the substrate. If needed, use a small trowel to work the material into the required opening or defect.

**CAUTION!** All substrates must be completely dry prior to the application of sealer.

6. When used as a penetration pan filler: When filling the Lockin' Pocket with Lockin' Pocket filler, the entire pocket must be filled, no grouts or fillers will be accepted. Approved pitch pans must be filled with a minimum of 2" (5.1cm) of Lockin' Pocket filler and in accordance with all of Nuralite's current application instructions. Penetrations must be prepared by wire brushing to remove loose cements, residual sealer, rust, or other contaminants. If pocket or penetration is damp prior to application, thoroughly dry or wipe with a solvent wipe or primer wipe and allow to dry before adding sealant.

7. Unused material can be applied at a later date by simply plugging the cartridges (with provided half-moon plugs) and using a new mixing nozzle.

#### AREAS OF USE

Nuralite's Lockin' Pocket is a multi-purpose sealer that finds application in:

- Repairing splits, cracks, holes, and other membrane defects
- Attaching lightning protection
- Repairing shingles
- All-purpose sealing



## NURAPLY 3P COVERED MEMBRANE INSTALLATION MANUAL

---

### APPROVED SUBSTRATES

Lockin' Pocket can be used on Nuraply 3PM or Nuraply systems, as well as other substrates in the list below.

- Concrete
- Gypsum
- Cementitious wood fiber
- Steel
- Gravel surfaced built-up roofs
- Base sheets (sanded or smooth surfaced)
- Smooth built-up roof surfaces
- Modified Bitumen (sanded or granule surfaced only)
- Metal panels
- Lightweight insulating concrete (LWIC)
- Gravel surfaced built-up roofs
- EPDM
- TPO

### EQUIPMENT

The fast and dependable applicators make applying Lockin' Pocket filler simple:

- Battery Powered Applicator
- Lockin' Pocket
- Lockin' Pocket filler
- Lockin' Pocket LPS Sealant

### STORAGE

Keep temperature of contents between 18°C - 29°C 24 hours prior to use. Do not store in direct sunlight or temperatures higher than 32°C.

### SURFACE PREPARATION

All work surfaces should be clean, dry, and free of dirt, dust, debris, oils, loose and/or embedded gravel, un-adhered coatings, deteriorated membrane and other contaminants that may result in a surface that is not sound or is uneven. For applications on granule surfaced modified bitumen membranes, remove all loose granules from the surface of the membrane prior to installing Lockin' Pocket LPS Sealer.

When Lockin' Pocket filler is to be used in a Lockin' Pocket installed on a single ply membrane, the surface of the membrane must be prepared according to the single ply manufacturer's recommendations. As a general guideline, the following methods of surface preparation shall apply:

- EPDM: Clean with splice wash or surface cleaner and prime with manufacturer's EPDM primer
- TPO: Clean with surface cleaner and prime.
- Gravel BUR's: Remove gravel surfacing down to plies

For applications, over existing weathered asphalt or coal tar pitch BUR, apply Lockin' Pocket Sealant prior to the application of Lockin' Pocket filler. For applications, over fresh and/or non-oxidized asphalt, coal tar or plastic film membranes, also apply Lockin' Pocket Sealant prior to the application of Lockin' Pocket filler.

### SAFETY

Prior to working with this or any adhesive product consult product label and Safety Data Sheet (SDS) for necessary health and safety precautions.

### LIMITATIONS

- Do not apply to wet or damp surfaces.
- Not intended for insulation attachment.
- Maximum two-minute working time between filling pockets, over two minutes requires a new static mixer to be attached to the cartridge.
- Keep applicator tool in horizontal position and invert just prior to dispensing to prevent premature mis-mix in the static mixer.

---

**NURACOAT BG**  
**TECHNICAL DATA SHEET**

---

**DESCRIPTION**

Nuracoat BG adhesive is a water based high performance ready to use, cold applied, high build liquid waterproofing membrane based on a polymer modified bitumen binder system.

Nuracoat BG forms a durable, highly elastic films that adheres well to most common substrates e.g. Enertherm PIR, Nuraply bitumen membranes, concrete, cementitious products and wood. Nuracoat BG is highly resistant to chlorides and sulphates commonly present in soil.

**SPECIFICATION**

Type:	Polymer modified bitumen emulsion.
Colour:	Black.
Viscosity:	Brushable or spreadable.
Moisture Vapour Transmission:	0.24g/m <sup>2</sup> /24hrs.
Cleaner:	Water while wet, Bostik Solvent No.2 or 3 when dry.
Stability:	Protect from frost.

**APPLICATION**

All surfaces must be clean and free from grease, oil, release agents or dust etc. It can be applied using brush, roller or squeegee.

When two or more coats are required, ensure that the preceding coat is fully dry before applying the successive coat, which should be applied at right angle to preceding coat. Nuracoat BG is not suited for high UV exposure and must be painted over if using above ground.

Always apply on a clear, warm sunny day with the temperature above 13°C.

NOTE: Enertherm PIR is to have 150mm foil tape on all exposed edges and 48mm foil tape on all joins before the application of the Nuracoat BG.

Nuradrain is to be installed once the Nuracoat BG is dry.

**COVERAGE**

1.1m<sup>2</sup>/L per coat.

**PACKAGING**

15 litre plastic pail.

**STORAGE**

Store in cool, dry conditions out of direct sunlight between 5° C and 25° C. This product MUST be protected from frost.

**SHELF LIFE**

12 months under normal temperature conditions and in original containers.



## NURAPLY 3P COVERED MEMBRANE INSTALLATION MANUAL

---

# NURADECK TECHNICAL DATA SHEET

---

### ACRYLIC ELASTOMER LIQUID MEMBRANE

#### DESCRIPTION AND AREAS OF USE

Liquid applied, seamless mastic with an outstanding balance of ease of use, elastic recovery, driven rain resistance, and long term durability and developed principally as a high build acrylic membrane which in combination with chopped strand fibreglass matt forms the basis of Nuralite Nuradeck decking & roofing system. Nuradeck is also an extremely effective semi-elastic high build wall coating in its own right and has found significant use for ensuring weather tightness against common hair-line cracking problems of solid plaster substrates for example but without the ultimate elastic "live-crack" bridging performance and cost of alternative **Nuracoat 300**. The all-acrylic resin nature of the product provides an unlimited choice of aesthetic finish, and unsurpassed ultraviolet and weather durability.

- o Excellent tensile strength, true stretch and recovery for permanent crack bridging without wrinkling or rupture.
- o Total and permanent resistance to wind driven rain.
- o In-film biocidal protection to restrict degradative mould and fungus growth.
- o Full recoatability and ease of maintenance and repair.
- o Fundamentally high adhesion to all common building material surfaces.
- o Barrier properties sufficient to prevent or halt concrete degradation due to carbon dioxide, chloride ion or "acid rain" ingress.
- o True acrylic polymer technology with superior longevity and durability of key performance parameters.
- o Waterborne for ease and safety of use and cleanup, and free from gross solvent hazard and pollution.
- o Standard finish is an aesthetically pleasing satin gloss - colour choice is unlimited.

Winter grade formulation available.

#### NURADECK

The properties of this product are such to allow simple, environmentally friendly and cost effective systems for weather and waterproofing of common exterior deck, patio and flat roofing. Nuradeck forms a permanent semi-elastic skin that combined with fibreglass reinforcement gives a tough and long wearing surface satisfactory for pedestrian traffic areas together with freedom of colour choice and long term aesthetic maintenance guaranteed by use of the best acrylic technology available. Deck/roof surfaces should be constructed in accordance with the NZBC, and aided by the BRANZ publication 'Good Membrane Roofing Practice'. Paying particular attention to the requirement that they must be sloped to be self-draining and not ponding, clean, dry and free of any friable weakness and appropriately primed, and then progressively coated to give a final high build laminate of Nuradeck reinforced with fibreglass matt. **Not for use in water retaining structures.**



## NURAPLY 3P COVERED MEMBRANE INSTALLATION MANUAL

---

### SPECIFICATION DATA

**Viscosity:** (Brookfield 6/10/200 C) 30,000 centipoise.

### DRY FILM

**Recommended Dry Film Build:** 7-800 micrometres

**Gloss & Colour:** Low gloss. Colour choice unlimited.

**Elongation:** @20°C = 100 % minimum (unreinforced).

**Tensile Strength:** 0.3 MPa.

**Water Swelling:** 24 hours 20 %

**Water Pondage (7 days):** No water transmission.

**Water Vapour Permeability:** Equivalent Air Layer Sd <0.5 metres (maximum 2 metres required).

**Carbon Dioxide Diffusion:** Equivalent Air Layer Sd >350 metres (minimum 50 metres required).

Packaging:	15 litre plastic resealable pails of concentrate
Shelflife	12 months minimum unopened
Specific Gravity	1.35
Shipping weight	21 kgs
Volume solids	50%
Expected Spread Rate	0.66m <sup>2</sup> per litre in combination with 300gm "E-Matt" fibreglass reinforcement

### HEALTH AND SAFETY

Non-Flammable. Alkaline-avoid eye and skin contact.

## NURAPLY 3P COVERED MEMBRANE INSTALLATION MANUAL

### MS DETAIL *IKOprotect MS Detail* TECHNICAL DATA SHEET

#### DESCRIPTION

MS Detail is a solvent-free, based off MS Polymer technology, grey coloured, liquid waterproofing systems that are applied with a brush. After reaction or polymerisation with the humidity present in the air, they form a waterproof skin around the finished roof detail, resulting in seamless waterproofing. In many cases, roof details are too complex to guarantee a waterproof finish using standard roof membranes.

#### AREAS OF APPLICATION

The system is specifically recommended for the waterproofing of roof details for roofs with technical installations and for roofs with complex shapes, in both new buildings and renovations. The system can also be used for the waterproofing of simple and complex roof details such as flashing, raised edges of domes or skylights, chimneys, ventilation lead-throughs, posts, scuppers, etc.

#### REINFORCING FLEECE

Non-woven polyester membrane used as reinforcement for the LIQUID WATERPROOFING of details, not affected by acids and most alkalis and bacteria. Use the strip at a width of  $\pm 12$  cm. **Not supplied by Nuralite**

Weight 30 g/m<sup>2</sup>  
Tensile strength lengthwise 52 N/ 5 cm  
Tensile strength crosswise 61 N/ 5 cm Tear resistance lengthwise 12 N  
Tear resistance crosswise 11.3 N  
Elongation at break, lengthwise 28 %  
Elongation at break, crosswise 34 %  
Thickness 0.13 mm

#### PREPARATION

All surfaces must be clean and free from grease, oil, release agents or dust etc. It can be applied using brush, roller or spray. The area around the detail should be outlined with masking tape in order to obtain a well-outlined finish for the detail.

NOTE: Concrete must be cured for a minimum of 28 days and have a moisture content of 18% or less. Plywood and timber must have a moisture content of 18% or less and be of the correct standards.

The below table shows a list of the substrates on which MS Detail can be applied, indicating whether the substrate should be pre-treated and primed first.

Substrate	MS Detail	Teknoprimer Detail
Nuraply 3PM & 3PTM	2	No
Steel	6 & 7	No
Aluminium	6 & 7	No
Copper	6 & 7	No
Zinc	6 & 7	No
Old Lead	6 & 7	No
Polyester	7	No
Concrete	Yes	8



## NURAPLY 3P COVERED MEMBRANE INSTALLATION MANUAL

Brick	Yes	8
Mortar	Yes	8
Natural Stone	No	No
Hard PE	No	No
Hard PVC	7	No
Acylate / PMMA	3	No
Polycarbonate	No	No
Timber	9	No

- 1) In the case of bituminous membranes finished with sand or talc, remove all loose sand or talc with a stiff brush before starting.
- 2) In the case of bituminous membranes finished with slate flakes or granulate, brush away any loose particles with a wire hand brush before starting.
- 3) An internal ageing test should be carried out first.
- 4) Roughen the membrane first using a belt sander, and then apply Quick Prime Plus.
- 5) Roughen the membrane first using a belt sander.
- 6) Sand down the metal to clean the substrate.
- 7) Pre-clean with methyl ethyl ketone (MEK) or Acetone solvent.
- 8) If the substrate is very porous, apply Teknoprimer Detail first. The substrate must be clean, dry and free from dust and loose particles, and must have cured for a minimum of 28 days. The relative humidity of the screed or concrete may not exceed 18%, measured on the wooden scale of a Protimeter.
- 9) Must have been pre-treated for outdoor use. Chipboard panels must be water-repellent.

Situations where these liquid waterproofing systems cannot be applied:

- On Teknoprimer Detail that is still moist or wet (drying time approx. 30 min.). The primer layer must have become transparent.
- Teknotan Detail cannot be applied indoors due to the odour. MS Detail can be applied indoors.
- If the temperature is below + 5°C, or if there is a risk that the temperature will drop below 5°C within 4 hours following the application.
- If the air temperature is above +35°C, and if the surface temperature is above +50°C.
- At a relative humidity degree above 85 %.
- During rainfall or in the case of fog.
- On substrates where the temperature is below + 5°C.
- On a frozen but dry substrate.
- In areas where capillary rising damp could occur (e.g., vapour diffusion within the building because there is no moisture barrier, or humidity from the soil in the case of a terrace on the ground floor because there is no moisture barrier under the concrete).
- On synthetic or rubber membranes that are not listed in Table 1.
- On hard polyethylene accessories.
- On polycarbonate boards.
- On natural stone.

### APPLICATION OF TEKNOPRIMER DETAIL

Apply Teknoprimer Detail with a brush or roller at a rate of 0.1 to 0.2 L/m<sup>2</sup>. Leave to dry in the open air for 30 minutes. The primer is applied to a distance of 1 cm beyond the surface that is to be treated.

### APPLICATION OF MS DETAIL

Never stir MS Detail!

- Open and close the lid of the packaging smoothly, without using force.
- The coating can be applied with a brush, a roller or a spatula.
- Adapt the size of the brush to the dimensions of the can.
- MS Detail can be applied in 1 layer or in 2 layers (wet-on-wet).



## **NURAPLY 3P COVERED MEMBRANE INSTALLATION MANUAL**

---

- If a layer of primer has been applied first, the outer edge of the LIQUID WATERPROOFING should be 1 cm inside the outer edge of the primed area.
- Remove the masking tape within 30 minutes of applying the product.

Follow the application instructions as described above.

For aesthetic reasons you can scatter slate flakes within the damp liquid waterproofing.

After a period of 30 minutes, it is no longer necessary to protect the layer from rain drops.

Always use non-woven Polyester tape when bridging different substrates and changing plains.

### **PACKAGING**

1 litre steel tin.

### **STORAGE**

Store in cool, dry conditions out of direct sunlight between 5° C and 25° C. This product **MUST** be protected from frost. Do not store upside down.

### **SHELF LIFE**

12 months in the hermetically sealed packaging under normal temperature conditions and in original containers. Once opened: use within 2 months. Do not store upside down.

**PU ADHESIVE  
TECHNICAL DATA SHEET**

---

**PU ADHESIVE FOR BONDING INSULATION BOARDS**

**DESCRIPTION AND USE**

IKOpro PU Adhesive is a permanent elastic high performance moisture-cured single part polyurethane adhesive with light foaming capacity for bonding bituminous roofing membranes, vapour control layers and rigid insulation boards.

-The adhesive is cold-applied and has been specially developed to allow the safe, rapid partial bonding of roofing components to a wide variety of substrates.

-IKOpro PU Adhesive is moisture-cured and tolerant of use in damp conditions. A degree of moisture is required, either in the atmosphere or on the surface, to allow the correct adhesive bond to be achieved. However, all liquid water should be removed from surfaces prior to use.

- For use on various substrates including profiled metal decking, existing bitumen membranes, concrete, timber etc.

**CURING TIME**

Curing time is dependent upon ambient temperature and humidity conditions however, curing will usually occur between 2 to 6 hours.

The adhesive will take 24 hours to achieve full bond strength.

**APPLICATION**

The minimum working temperature is 5°C. At low temperatures, warming the containers in hot water prior to use will improve handling characteristics. (N.B. Do not boil the product.) Maximum working temperature 30°C. Application time: max 20 minutes.

Surfaces to receive adhesive should be stable, clean and free of any liquid water (damp surfaces are acceptable).

No priming is required.

IKOpro PU Adhesive is applied straight from the container in strips at a rate of approximately 50 g per linear metre.

- Use spout on can for pouring lines of adhesive.

Four strips per metre width (200 g/m<sup>2</sup>) are usually sufficient for main roof areas.

For roof perimeter or corner zones or roofs in particularly exposed locations, more vulnerable to wind uplift, six strips per metre width (300 g/m<sup>2</sup>) should be applied.

The membrane or insulation should be applied and pressed into position before formation of a skin on the adhesive. It is recommended that the bond is checked from time to time, by lifting a corner of the insulation/membrane to ensure that the adhesive ridges have been squeezed flat. This is particularly important with uneven substrates.

**CLEANING**

- Trichloroethane or methylene chloride.

**PACKAGING**



## **NURAPLY 3P COVERED MEMBRANE INSTALLATION MANUAL**

---

- 6,50 kg can.

### **STORAGE**

Keep containers tightly closed when not in use. Store in its sealed container, in dry conditions at a temperature between 5°C and 25°C.

To avoid the risk of spillage, always store and transport in a secure upright position.

### **SHELF LIFE**

6 months in an unopened container, stored within the above temperature range.

### **HEALTH AND SAFETY**

- Keep container tightly sealed and away from direct heat. Keep away from sources of ignition. No smoking. Avoid contact with skin and eyes. Should there be contact with skin, wash immediately with soap and water or a recognized skin cleaner. In case of contact with eyes, rinse immediately with plenty of water and seek medical advice. In the event of accidents, seek medical attention immediately. Do not empty into drains. Do not allow solvent vapour to enter the air intakes of the ventilation systems of buildings.

### **FIRE**

- In case of fire, use foam, dry powder, carbon dioxide or sand. Never use water jet.

7/03/06 TF IKOpro PU Adhesive 6,50 kg 02401460-en.doc - lva -1/1

### **Transport Classification**

3YE

**NURADRAIN**  
**TECHNICAL DATA SHEET**

**DESCRIPTION AND AREAS OF USE**

A high-density polyethylene (HDPE) dimpled sheet. Specifically designed as a backfill protection and vertical drainage board for sub-grade tanking. Nuradrain is designed to reduce hydrostatic pressure behind walls by providing an unimpeded drainage path to the base drainage coil.

**FINISHING**

Black plastic sheet with 7.5mm dimples.

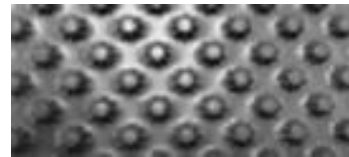

**APPLICATIONS**

Protection and drainage board for waterproofing membranes of below-grade tanking.

**COMPOSITION**

High density polyethylene (HDPE)

**TECHNICAL SPECIFICATIONS** (average values)

	<b>Value</b>	<b>Unit</b>	<b>Standard</b>
N. of dimples	1907	-	-
Compressive Strength	180 ±20%	KN/m <sup>2</sup>	UNE-EN-ISO 604
Tensile strength, approx.	>450	N/60mm	UNE EN 12311-1
Tear strength, approx.	>25	%	UNE EN 12311-1
Modules of elasticity	1500	N/mm <sup>2</sup>	ISO 178
Water absorption	1	mg/4d	DIN 53495
Drainage capacity, approx.	4.8	l/s.m	-
Temperature range	-30 a 80	°C	-
Air volume between nodules, approx.	5.9	l/m <sup>2</sup>	-

## NURAPLY 3P COVERED MEMBRANE INSTALLATION MANUAL

### DIMENSIONS

	Value	Unit
Length	28	m
Width	2.1	m
Dimple Height	7.3 ± 0.2	mm
Roll area	58.8	m <sup>2</sup>
Rolls per pallet	6	rolls

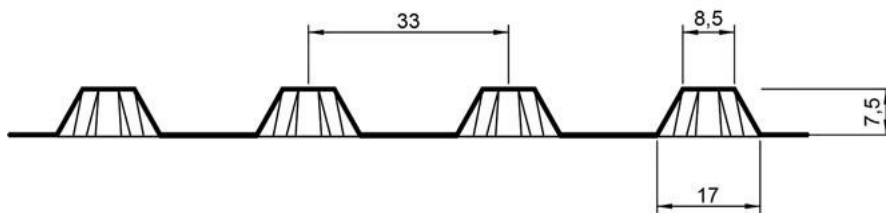

### INSTALLATION NOTES

Raised side of Nuradrain to be installed against the membrane. Can be held in place prior to back fill with either, Nuralite adhesive tape supplied by Nuralite, sand bagging or Nuradrain self-adhesive mechanical fixings supplied by Nuralite.

Overlap sheets joints at 120mm horizontally and 200mm vertically and hold in place with Nuralite adhesive tape.

Initial backfilling should be by hand around the base of Nuradrain but can be completed mechanically. Care must be taken to prevent damage to Nuradrain during the back filling process. Fix in place the Nuradrain termination bar before back filling is completed.

Nuradrain can withstand the lateral load applied by compaction equipment up to 100mm from the face. Excessive compaction force should be avoided.

### SAFETY, STORAGE & HANDLING INFORMATION

Do not stack pallets

Store indoors

### TRANSPORT

CLASSIFICATION N/A



---

## **NURAPLY 3P COVERED MEMBRANE INSTALLATION MANUAL**

---

### **TYPE AND MATERIAL**

Upper face: Non -woven needle-punched and heat-treated long stable fibre polypropylene

Lower face: Non-woven felt of polypropylene and other recycled polymers

### **PRODUCT DIMENSIONS**

920mm x 50m. The product is normally rolled with the lower textile inward and will require to be turned over during installation.

### **NOTES**

1. The values given are indicative and correspond to nominal results obtained in the manufacturers laboratories and testing institutes.
2. The tolerance on roll length is  $\pm 1.5\%$  and on roll width is  $\pm 1.0\%$ .
3. Guidance on interface shear strength, creep and certain other parameters is available. Site specific tests are strongly recommended.
4. Non-load bearing walls can be built off **GREENDRAIN**.
5. The hydraulic performance of the lower face textile does not influence overall product performance.

### **SAFETY, STORAGE & HANDLING INFORMATION**

Do not stack pallets

Store indoors

### **TRANSPORT CLASSIFICATION**

N/A





## **NURAPLY 3P COVERED MEMBRANE INSTALLATION MANUAL**

---

### **12. Installation Details**

This drawing is indicative only and not for construction. This detail depicts Nuralite products and components for correct use as per the installation manual. All other elements are typical only - refer to the designer. Always refer to original colour details when printing.

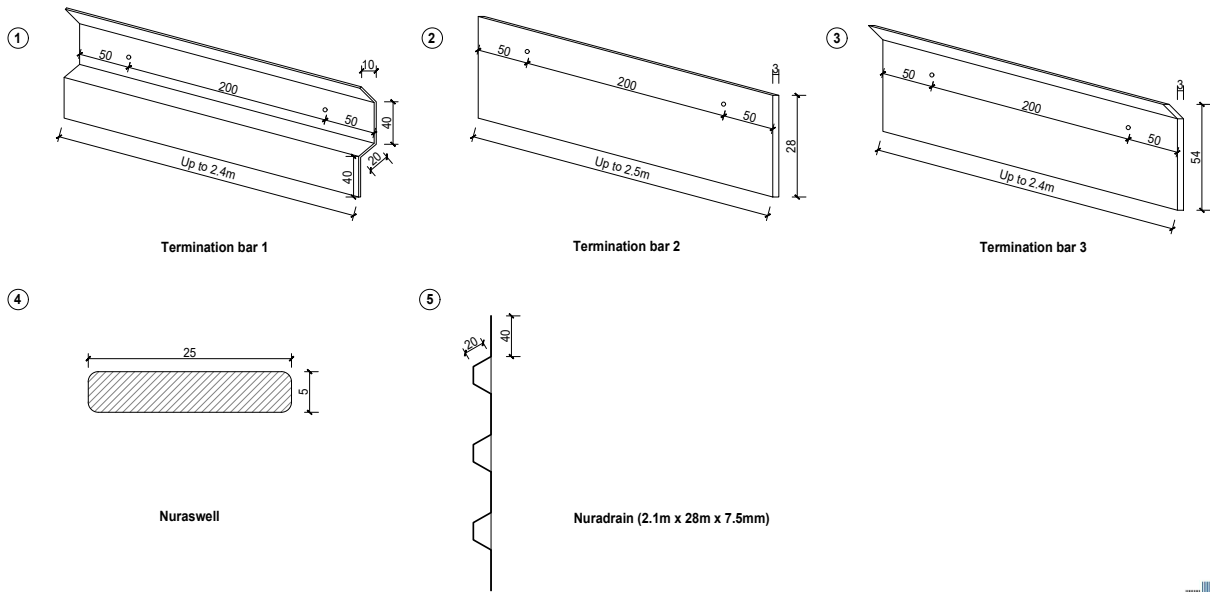

All Nuralite products/systems to be installed by an authorized Nuralite applicator and in accordance with Nuralite published instruction. Product data sheets should be consulted at all times. This drawing is a guide and is not for construction. This detail drawing is to be used only as part of the Nuralite specification package. All drawings are subject to copyright. Unauthorized use is prohibited. © Nuralite Waterproofing Ltd  
0800 - NURALITE (687254) www.nuralite.co.nz

PRODUCT/SYSTEM: **NURAPLY 3PT & 3PTM TANKING**

DETAIL: **ASSESSORY PAGE**

SCALE: **NTS** DATE: **SEP 2018** PREVIOUS DWG no: - REVISION: **1** DWG no:

This drawing is indicative only and not for construction. This detail depicts Nuralite products and components for correct use as per the installation manual. All other elements are typical only - refer to the designer. Always refer to original colour details when printing.

**Note:**  
For waterproofing the lower storey of a building wholly or partially below ground. Buildings with deep multi-storey basements require specialised, bespoke, designs.

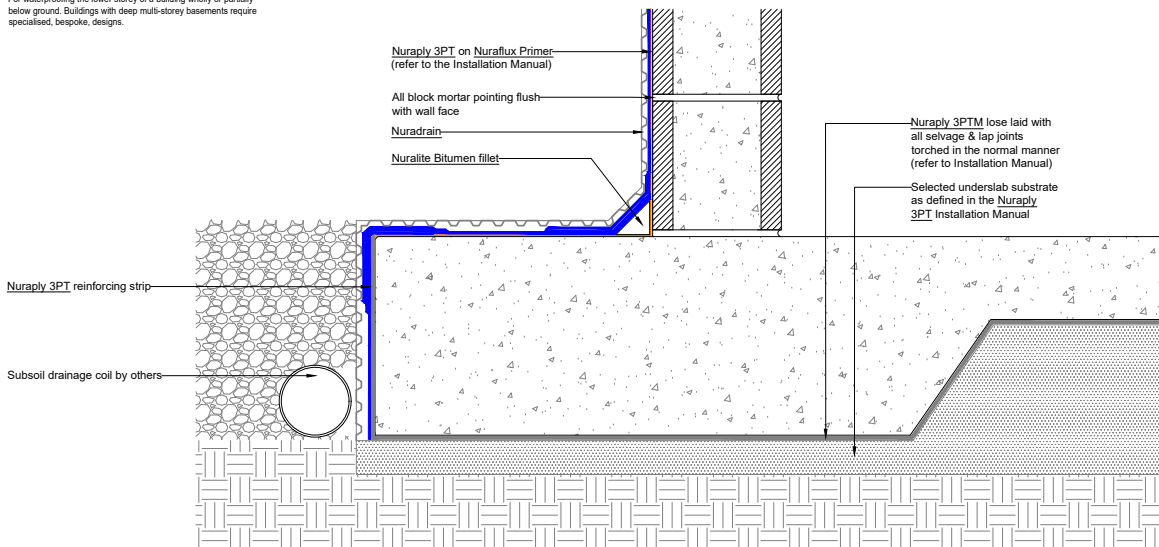

All Nuralite products/systems to be installed by an authorized Nuralite applicator and in accordance with Nuralite published instruction. Product data sheets should be consulted at all times. This drawing is a guide and is not for construction. This detail drawing is to be used only as part of the Nuralite specification package. All drawings are subject to copyright. Unauthorized use is prohibited. © Nuralite Waterproofing Ltd  
0800 - NURALITE (687254) www.nuralite.co.nz

PRODUCT/SYSTEM: **NURAPLY 3PT & 3PTM TANKING**

DETAIL: **TOE DETAIL**

SCALE: **NTS** DATE: **SEP 2018** PREVIOUS DWG no: - REVISION: **1** DWG no: **TCP-A1**

This drawing is indicative only and not for construction. This detail depicts Nuralite products and components for correct use as per the installation manual. All other elements are typical only - refer to the designer. Always refer to original colour details when printing.

**Note:**  
For waterproofing the lower storey of a building wholly or partially below ground. Buildings with deep multi-storey basements require specialised, bespoke, designs.

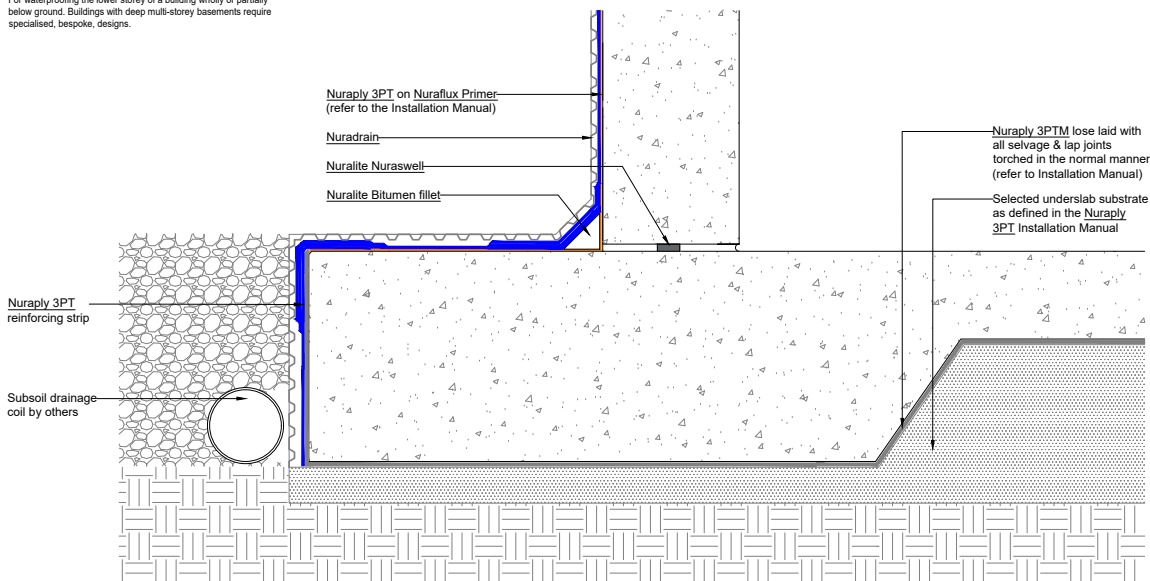

All Nuralite products/systems to be installed by an authorized Nuralite applicator and in accordance with Nuralite published instruction. Product data sheets should be consulted at all times. This drawing is a guide and is not for construction. This detail drawing is to be used only as part of the Nuralite specification package. All drawings are subject to copyright. Unauthorized use is prohibited. © Nuralite Waterproofing Ltd  
0800 - NURALITE (687254) www.nuralite.co.nz

PRODUCT/SYSTEM:	<b>NURAPLY 3PT &amp; 3PTM TANKING</b>		
DETAIL:	PRECAST TO TOE DETAIL		
SCALE: NTS	DATE: <b>SEP 2018</b>	PREVIOUS DWG no: -	REVISION: <b>1</b> DWG no: <b>TCP-.A2</b>

This drawing is indicative only and not for construction. This detail depicts Nuralite products and components for correct use as per the installation manual. All other elements are typical only - refer to the designer. Always refer to original colour details when printing.

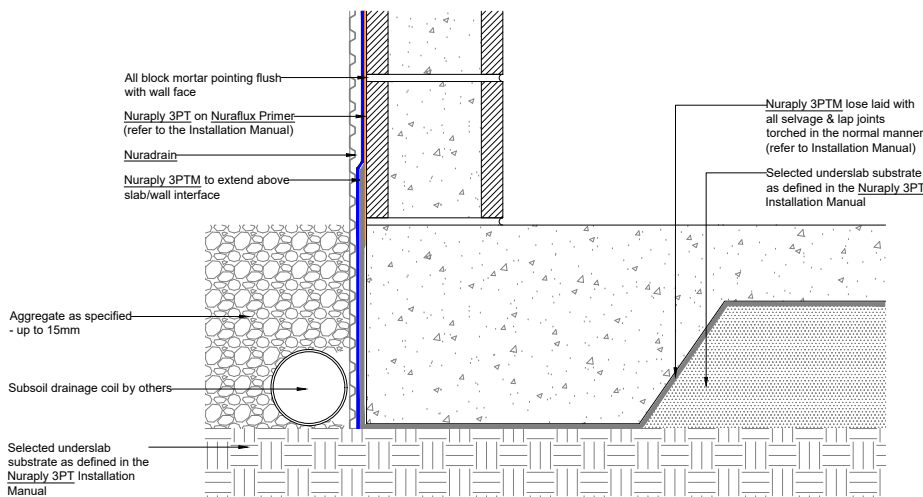

**Note:**  
For waterproofing the lower storey of a building wholly or partially below ground. Buildings with deep multi-storey basements require specialised, bespoke, designs.



All Nuralite products/systems to be installed by an authorized Nuralite applicator and in accordance with Nuralite published instruction. Product data sheets should be consulted at all times. This drawing is a guide and is not for construction. This detail drawing is to be used only as part of the Nuralite specification package. All drawings are subject to copyright. Unauthorized use is prohibited. © Nuralite Waterproofing Ltd  
0800 - NURALITE (687254) www.nuralite.co.nz

PRODUCT/SYSTEM:	<b>NURAPLY 3PT &amp; 3PTM TANKING</b>		
DETAIL:	BASEMENT FOOTING		
SCALE: NTS	DATE: <b>SEP 2018</b>	PREVIOUS DWG no: -	REVISION: <b>1</b> DWG no: <b>TCP-.B1</b>

This drawing is indicative only and not for construction. This detail depicts Nuralite products and components for correct use as per the installation manual. All other elements are typical only - refer to the designer. Always refer to original colour details when printing.

**Note:**  
Bond the PIR with Sella's Water Based Kwik Grip Gel. Tape any exposed edges of PIR with 150mm foil tape before installing. Tape all PIR joins with 48mm foil tape once installed and before coating with Nuracoat BC.

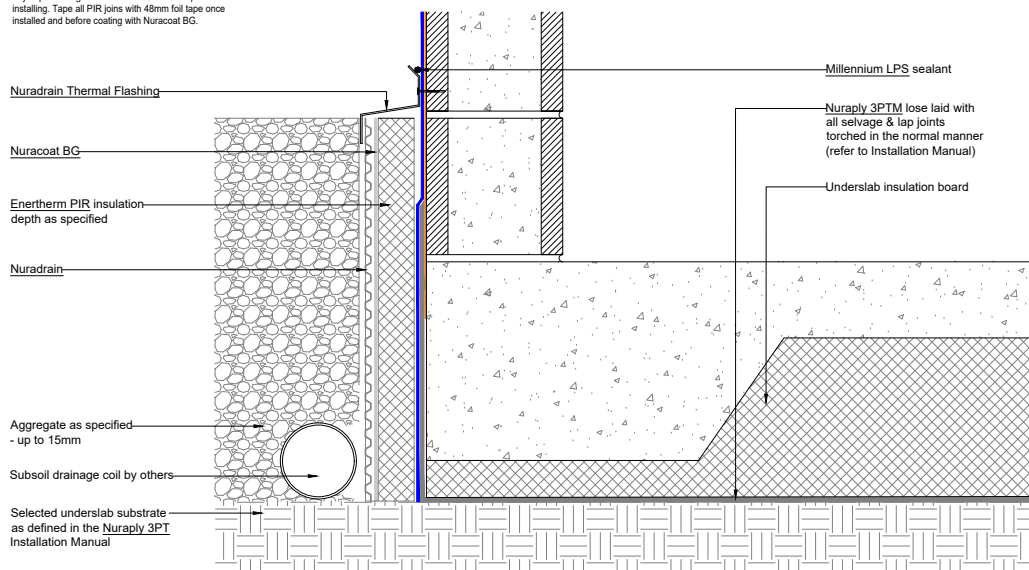

All Nuralite products/systems to be installed by an authorized Nuralite applicator and in accordance with Nuralite published instruction. Product data sheets should be consulted at all times. This drawing is a guide and is not for construction. This detail drawing is to be used only as part of the Nuralite specification package. All drawings are subject to copyright. Unauthorized use is prohibited. © Nuralite Waterproofing Ltd  
0800 - NURALITE (687254) www.nuralite.co.nz

PRODUCT/SYSTEM:

**NURAPLY 3PT & 3PTM TANKING**

DETAIL:

**BASEMENT FOOTING WITH FULL INSULATION**

SCALE: NTS DATE: **SEP 2018**

PREVIOUS DWG no: -

REVISION: 1

DWG no: **TCP-.B2**



This drawing is indicative only and not for construction. This detail depicts Nuralite products and components for correct use as per the installation manual. All other elements are typical only - refer to the designer. Always refer to original colour details when printing.

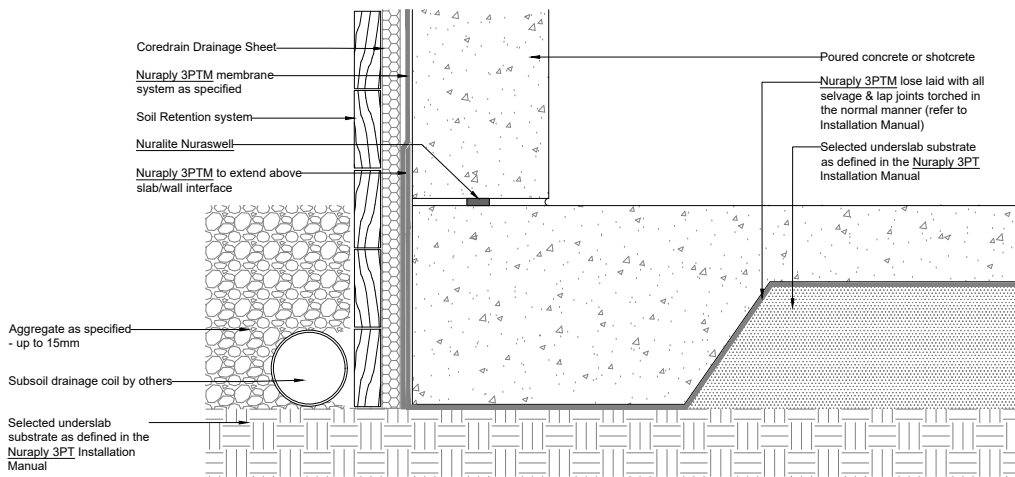

All Nuralite products/systems to be installed by an authorized Nuralite applicator and in accordance with Nuralite published instruction. Product data sheets should be consulted at all times. This drawing is a guide and is not for construction. This detail drawing is to be used only as part of the Nuralite specification package. All drawings are subject to copyright. Unauthorized use is prohibited. © Nuralite Waterproofing Ltd  
0800 - NURALITE (687254) www.nuralite.co.nz

PRODUCT/SYSTEM:

**NURAPLY 3PT & 3PTM TANKING**

DETAIL:

**BLINDSIDE WALL TO SLAB TIE IN**

SCALE: NTS DATE: **SEP 2018**

PREVIOUS DWG no: -

REVISION: 1

DWG no: **TCP-.B3**



This drawing is indicative only and not for construction. This detail depicts Nuralite products and components for correct use as per the installation manual. All other elements are typical only - refer to the designer. Always refer to original colour details when printing.

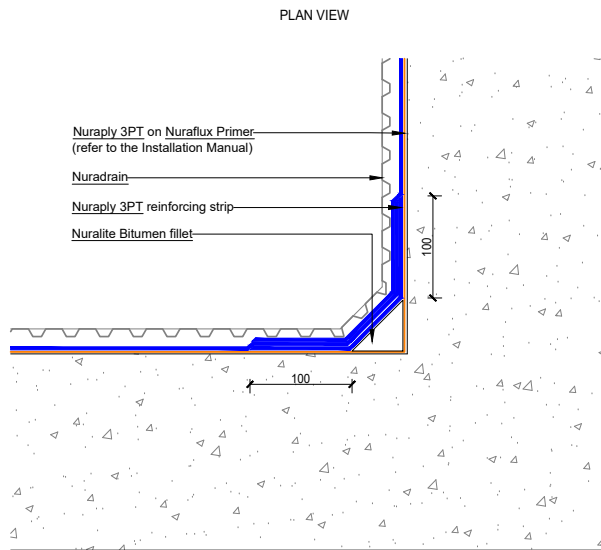

**Note:**  
For waterproofing the lower storey of a building wholly or partially below ground. Buildings with deep multi-storey basements require specialised, bespoke, designs.



All Nuralite products/systems to be installed by an authorized Nuralite applicator and in accordance with Nuralite published instruction. Product data sheets should be consulted at all times. This drawing is a guide and is not for construction. This detail drawing is to be used only as part of the Nuralite specification package. All drawings are subject to copyright. Unauthorized use is prohibited. © Nuralite Waterproofing Ltd  
0800 - NURALITE (687254) www.nuralite.co.nz



PRODUCT/SYSTEM:	<b>NURAPLY 3PT &amp; 3PTM TANKING</b>		
DETAIL:	INTERNAL CORNER		
SCALE: NTS	DATE: <b>SEP 2018</b>	PREVIOUS DWG no: -	REVISION: <b>1</b> DWG no: <b>TCP-.C1</b>

This drawing is indicative only and not for construction. This detail depicts Nuralite products and components for correct use as per the installation manual. All other elements are typical only - refer to the designer. Always refer to original colour details when printing.

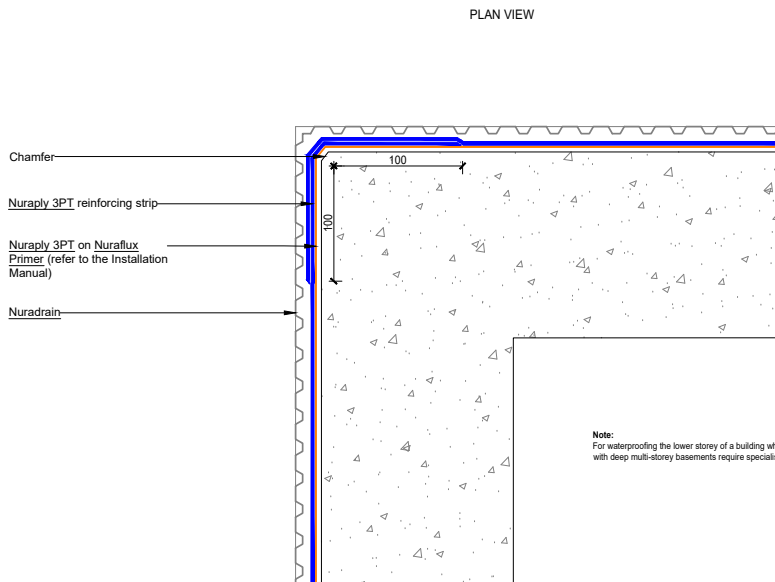

**Note:**  
For waterproofing the lower storey of a building wholly or partially below ground. Buildings with deep multi-storey basements require specialised, bespoke, designs.



All Nuralite products/systems to be installed by an authorized Nuralite applicator and in accordance with Nuralite published instruction. Product data sheets should be consulted at all times. This drawing is a guide and is not for construction. This detail drawing is to be used only as part of the Nuralite specification package. All drawings are subject to copyright. Unauthorized use is prohibited. © Nuralite Waterproofing Ltd  
0800 - NURALITE (687254) www.nuralite.co.nz



PRODUCT/SYSTEM:	<b>NURAPLY 3PT &amp; 3PTM TANKING</b>		
DETAIL:	EXTERNAL CORNER		
SCALE: NTS	DATE: <b>SEP 2018</b>	PREVIOUS DWG no: -	REVISION: <b>1</b> DWG no: <b>TCP-.D1</b>

This drawing is indicative only and not for construction. This detail depicts Nuralite products and components for correct use as per the installation manual. All other elements are typical only - refer to the designer. Always refer to original colour details when printing.

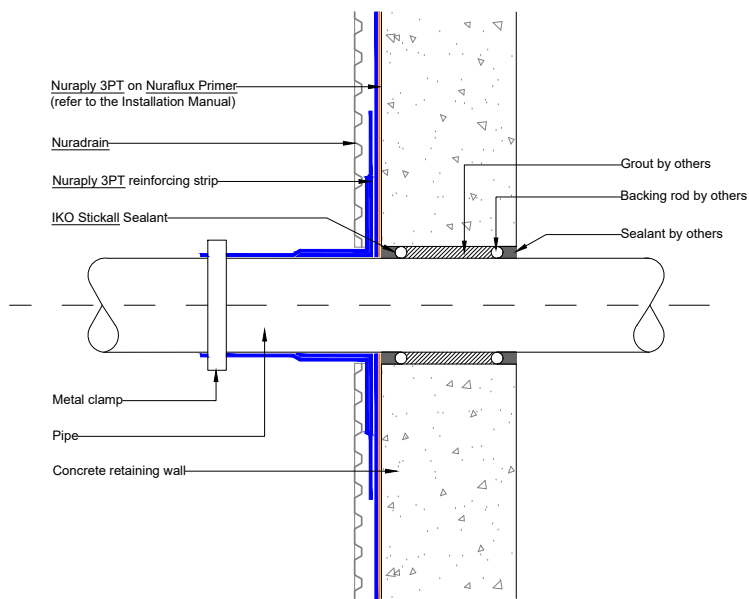

**Note:**  
For waterproofing the lower storey of a building wholly or partially below ground. Buildings with deep multi-storey basements require specialised, bespoke, designs.



All Nuralite products/systems to be installed by an authorized Nuralite applicator and in accordance with Nuralite published instruction. Product data sheets should be consulted at all times. This drawing is a guide and is not for construction. This detail drawing is to be used only as part of the Nuralite specification package. All drawings are subject to copyright. Unauthorized use is prohibited. © Nuralite Waterproofing Ltd  
0800 - NURALITE (687254) www.nuralite.co.nz

PRODUCT/SYSTEM:	<b>NURAPLY 3PT &amp; 3PTM TANKING</b>		
DETAIL:	CONCRETE WALL PENETRATION		
SCALE: NTS	DATE: <b>SEP 2018</b>	PREVIOUS DWG no: -	REVISION: <b>1</b> DWG no: <b>TCP-E1</b>

This drawing is indicative only and not for construction. This detail depicts Nuralite products and components for correct use as per the installation manual. All other elements are typical only - refer to the designer. Always refer to original colour details when printing.

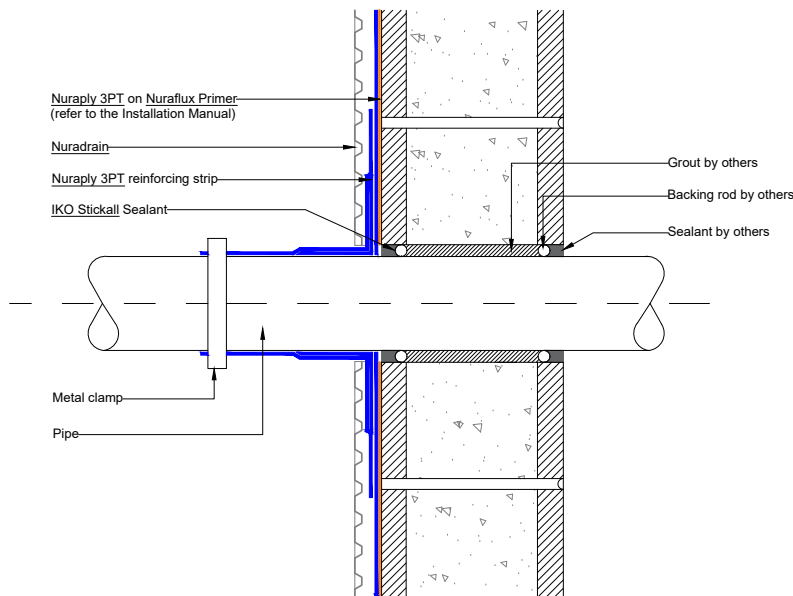

**Note:**  
For waterproofing the lower storey of a building wholly or partially below ground. Buildings with deep multi-storey basements require specialised, bespoke, designs.



All Nuralite products/systems to be installed by an authorized Nuralite applicator and in accordance with Nuralite published instruction. Product data sheets should be consulted at all times. This drawing is a guide and is not for construction. This detail drawing is to be used only as part of the Nuralite specification package. All drawings are subject to copyright. Unauthorized use is prohibited. © Nuralite Waterproofing Ltd  
0800 - NURALITE (687254) www.nuralite.co.nz

PRODUCT/SYSTEM:	<b>NURAPLY 3PT &amp; 3PTM TANKING</b>		
DETAIL:	BLOCK WALL PENETRATION		
SCALE: NTS	DATE: <b>SEP 2018</b>	PREVIOUS DWG no: -	REVISION: <b>1</b> DWG no: <b>TCP-E2</b>

This drawing is indicative only and not for construction. This detail depicts Nuralite products and components for correct use as per the installation manual. All other elements are typical only - refer to the designer. Always refer to original colour details when printing.

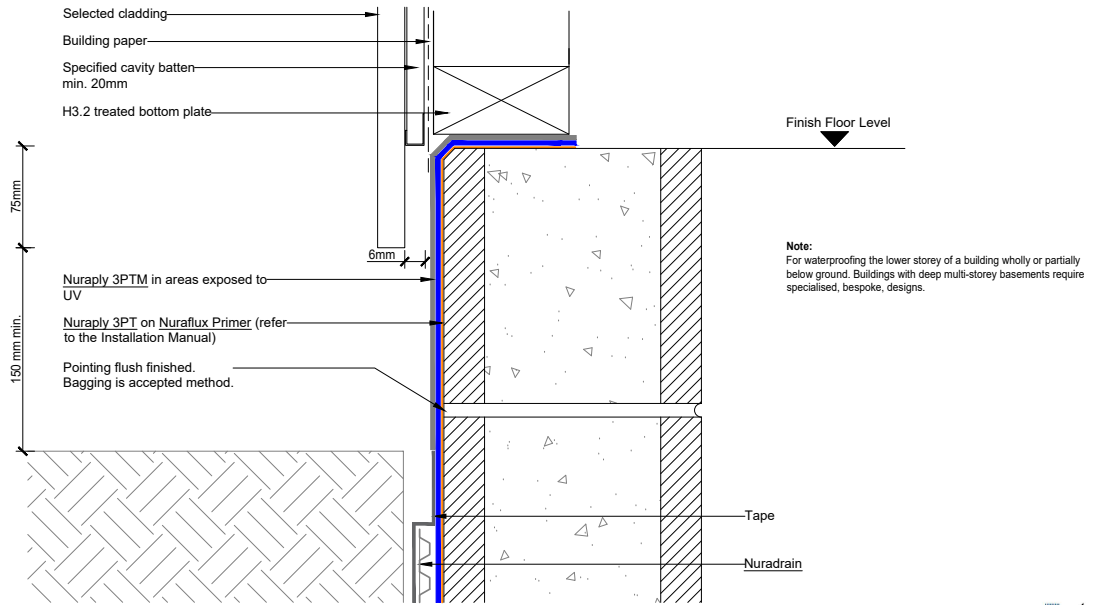

All Nuralite products/systems to be installed by an authorized Nuralite applicator and in accordance with Nuralite published instruction. Product data sheets should be consulted at all times. This drawing is a guide and is not for construction. This detail drawing is to be used only as part of the Nuralite specification package. All drawings are subject to copyright. Unauthorized use is prohibited. © Nuralite Waterproofing Ltd  
0800 - NURALITE (687254) www.nuralite.co.nz

PRODUCT/SYSTEM: **NURAPLY 3PT & 3PTM TANKING**  
 DETAIL: **TERMINATION UNDER BOTTOM PLATE**  
 SCALE: NTS DATE: **SEP 2018** PREVIOUS DWG no: - REVISION: **1** DWG no: **TCP-.F1**

This drawing is indicative only and not for construction. This detail depicts Nuralite products and components for correct use as per the installation manual. All other elements are typical only - refer to the designer. Always refer to original colour details when printing.

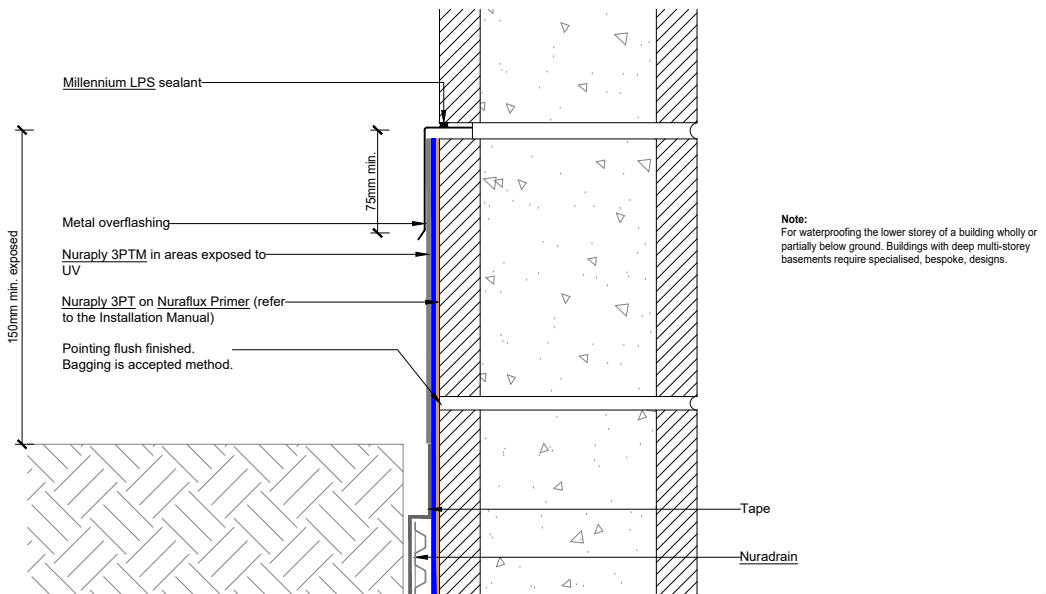

All Nuralite products/systems to be installed by an authorized Nuralite applicator and in accordance with Nuralite published instruction. Product data sheets should be consulted at all times. This drawing is a guide and is not for construction. This detail drawing is to be used only as part of the Nuralite specification package. All drawings are subject to copyright. Unauthorized use is prohibited. © Nuralite Waterproofing Ltd  
0800 - NURALITE (687254) www.nuralite.co.nz

PRODUCT/SYSTEM: **NURAPLY 3PT & 3PTM TANKING**  
 DETAIL: **TERMINATION INTO CHASE**  
 SCALE: NTS DATE: **SEP 2018** PREVIOUS DWG no: - REVISION: **1** DWG no: **TCP-.F2**

This drawing is indicative only and not for construction. This detail depicts Nuralite products and components for correct use as per the installation manual. All other elements are typical only - refer to the designer. Always refer to original colour details when printing.

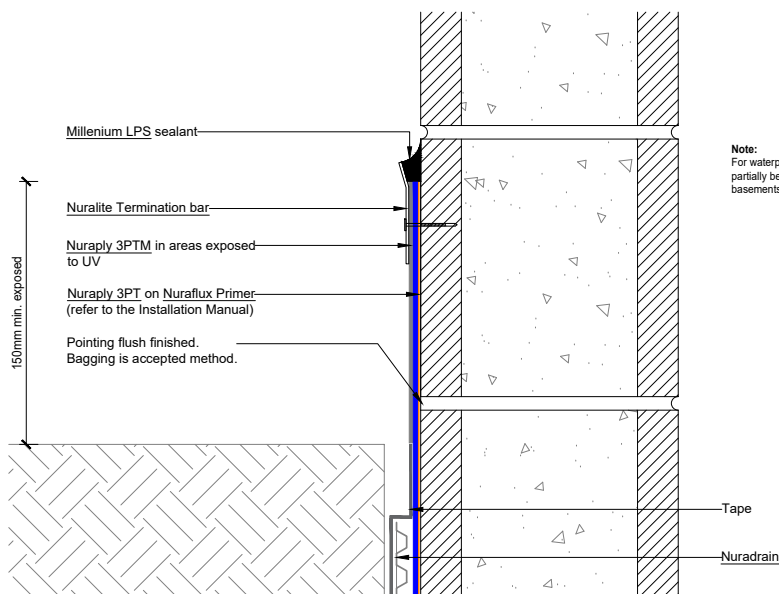

**Note:**  
For waterproofing the lower storey of a building wholly or partially below ground. Buildings with deep multi-storey basements require specialised, bespoke, designs.



All Nuralite products/systems to be installed by an authorized Nuralite applicator and in accordance with Nuralite published instruction. Product data sheets should be consulted at all times. This drawing is a guide and is not for construction. This detail drawing is to be used only as part of the Nuralite specification package. All drawings are subject to copyright. Unauthorized use is prohibited. © Nuralite Waterproofing Ltd  
0800 - NURALITE (687254) www.nuralite.co.nz

PRODUCT/SYSTEM:	<b>NURAPLY 3PT &amp; 3PTM TANKING</b>		
DETAIL:	TERMINATION USING TERMINATION BAR		
SCALE: NTS	DATE: <b>SEP 2018</b>	PREVIOUS DWG no: -	REVISION: <b>1</b> DWG no: <b>TCP-.F3</b>

This drawing is indicative only and not for construction. This detail depicts Nuralite products and components for correct use as per the installation manual. All other elements are typical only - refer to the designer. Always refer to original colour details when printing.

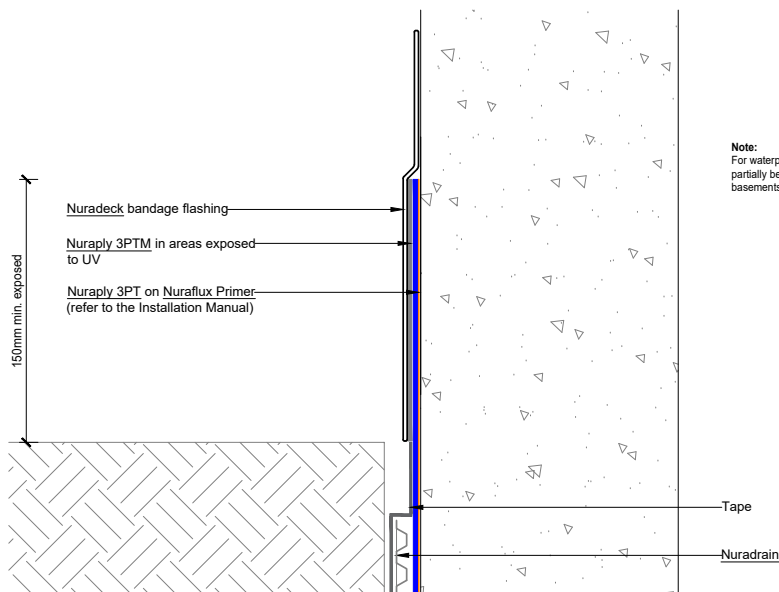

**Note:**  
For waterproofing the lower storey of a building wholly or partially below ground. Buildings with deep multi-storey basements require specialised, bespoke, designs.



All Nuralite products/systems to be installed by an authorized Nuralite applicator and in accordance with Nuralite published instruction. Product data sheets should be consulted at all times. This drawing is a guide and is not for construction. This detail drawing is to be used only as part of the Nuralite specification package. All drawings are subject to copyright. Unauthorized use is prohibited. © Nuralite Waterproofing Ltd  
0800 - NURALITE (687254) www.nuralite.co.nz

PRODUCT/SYSTEM:	<b>NURAPLY 3PT &amp; 3PTM TANKING</b>		
DETAIL:	TERMINATION USING NURADECK BANDAGE FLASHING		
SCALE: NTS	DATE: <b>SEP 2018</b>	PREVIOUS DWG no: -	REVISION: <b>1</b> DWG no: <b>TCP-.F4</b>



This drawing is indicative only and not for construction. This detail depicts Nuralite products and components for correct use as per the installation manual. All other elements are typical only - refer to the designer. Always refer to original colour details when printing.

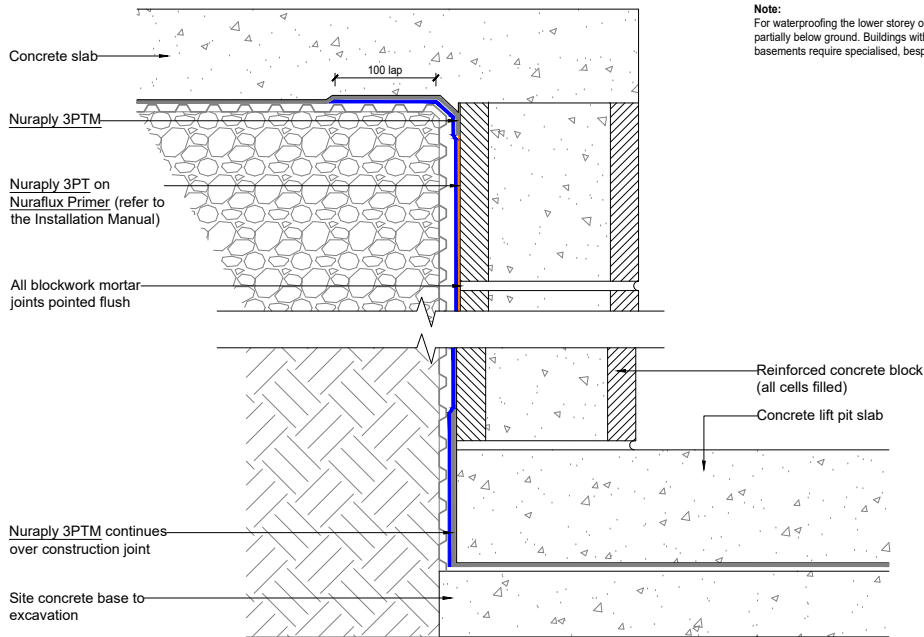

**Note:**  
For waterproofing the lower storey of a building wholly or partially below ground. Buildings with deep multi-storey basements require specialised, bespoke, designs.



All Nuralite products/systems to be installed by an authorized Nuralite applicator and in accordance with Nuralite published instruction. Product data sheets should be consulted at all times. This drawing is a guide and is not for construction. This detail drawing is to be used only as part of the Nuralite specification package. All drawings are subject to copyright. Unauthorized use is prohibited. © Nuralite Waterproofing Ltd  
0800 - NURALITE (687254) www.nuralite.co.nz

PRODUCT/SYSTEM:	<b>NURAPLY 3PT &amp; 3PTM TANKING</b>		
DETAIL:	LIFT PIT		
SCALE: NTS	DATE: <b>SEP 2018</b>	PREVIOUS DWG no: -	REVISION: <b>1</b> DWG no: <b>TCP-G1</b>

This drawing is indicative only and not for construction. This detail depicts Nuralite products and components for correct use as per the installation manual. All other elements are typical only - refer to the designer. Always refer to original colour details when printing.

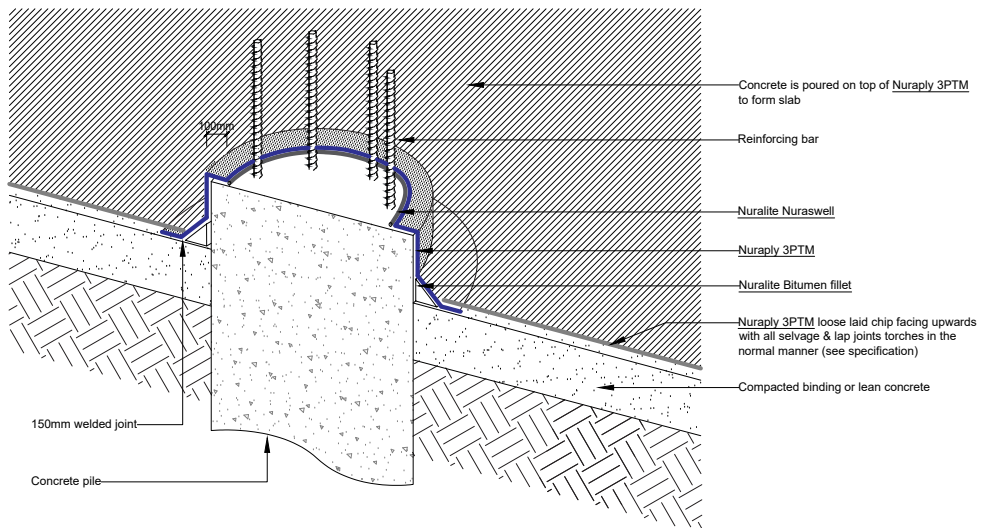

ISOMETRIC



All Nuralite products/systems to be installed by an authorized Nuralite applicator and in accordance with Nuralite published instruction. Product data sheets should be consulted at all times. This drawing is a guide and is not for construction. This detail drawing is to be used only as part of the Nuralite specification package. All drawings are subject to copyright. Unauthorized use is prohibited. © Nuralite Waterproofing Ltd  
0800 - NURALITE (687254) www.nuralite.co.nz

PRODUCT/SYSTEM:	<b>NURAPLY 3PT &amp; 3PTM TANKING</b>		
DETAIL:	PILE HEAD DETAIL		
SCALE: NTS	DATE: <b>SEP 2018</b>	PREVIOUS DWG no: -	REVISION: <b>1</b> DWG no: <b>TCP.H1 iso</b>

This drawing is indicative only and not for construction. This detail depicts Nuralite products and components for correct use as per the installation manual. All other elements are typical only - refer to the designer. Always refer to original colour details when printing.

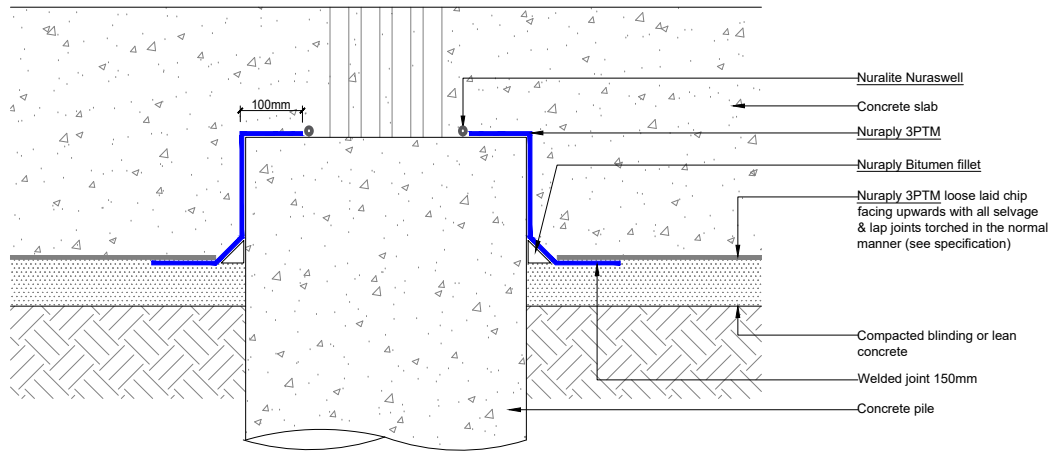

**Note:**  
Tanking under the slab must be considered when slab FFL (finished floor level) is 300mm below outside FFL.



All Nuralite products/systems to be installed by an authorized Nuralite applicator and in accordance with Nuralite published instruction. Product data sheets should be consulted at all times. This drawing is a guide and is not for construction. This detail drawing is to be used only as part of the Nuralite specification package. All drawings are subject to copyright. Unauthorized use is prohibited. © Nuralite Waterproofing Ltd  
0800 - NURALITE (687254) www.nuralite.co.nz

PRODUCT/SYSTEM:	<b>NURAPLY 3PT &amp; 3PTM TANKING</b>		
DETAIL:	PILE HEAD		
SCALE: NTS	DATE: <b>SEP 2018</b>	PREVIOUS DWG no: -	REVISION: 1 DWG no: <b>TCP-.H1</b>

This drawing is indicative only and not for construction. This detail depicts Nuralite products and components for correct use as per the installation manual. All other elements are typical only - refer to the designer. Always refer to original colour details when printing.

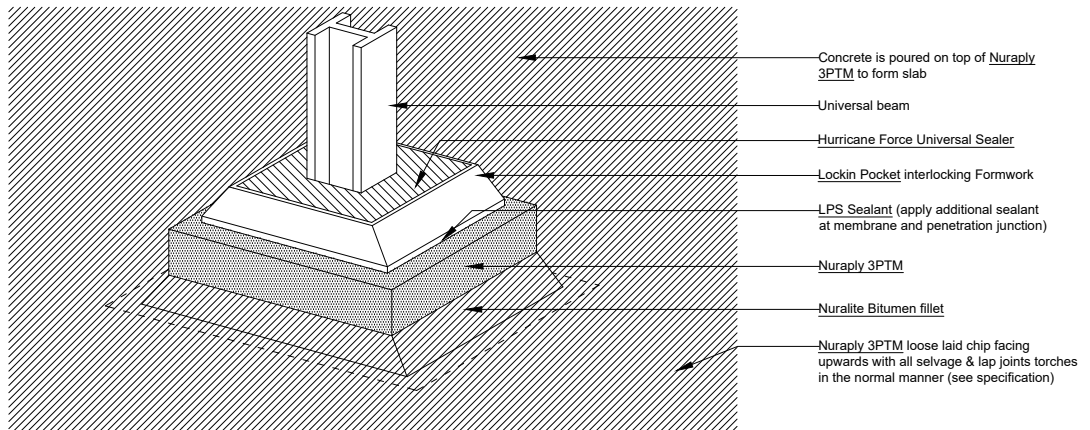

ISOMETRIC



All Nuralite products/systems to be installed by an authorized Nuralite applicator and in accordance with Nuralite published instruction. Product data sheets should be consulted at all times. This drawing is a guide and is not for construction. This detail drawing is to be used only as part of the Nuralite specification package. All drawings are subject to copyright. Unauthorized use is prohibited. © Nuralite Waterproofing Ltd  
0800 - NURALITE (687254) www.nuralite.co.nz

PRODUCT/SYSTEM:	<b>NURAPLY 3PT &amp; 3PTM TANKING</b>		
DETAIL:	PILE HEAD DETAIL		
SCALE: NTS	DATE: <b>SEP 2018</b>	PREVIOUS DWG no: -	REVISION: 1 DWG no: <b>TCP.H2 iso</b>

This drawing is indicative only and not for construction. This detail depicts Nuralite products and components for correct use as per the installation manual. All other elements are typical only - refer to the designer. Always refer to original colour details when printing.

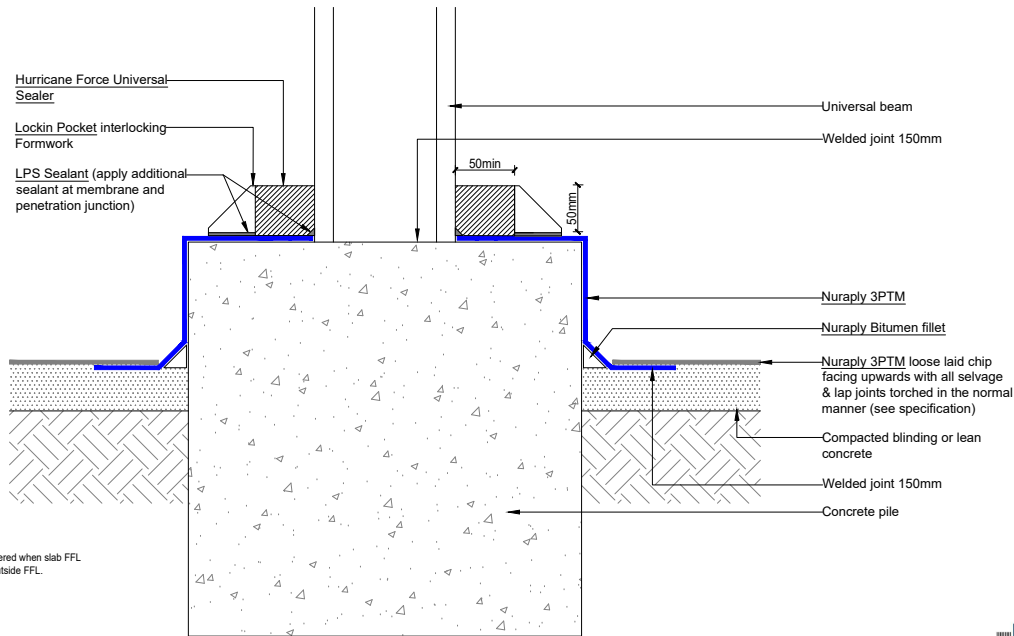

All Nuralite products/systems to be installed by an authorized Nuralite applicator and in accordance with Nuralite published instruction. Product data sheets should be consulted at all times. This drawing is a guide and is not for construction. This detail drawing is to be used only as part of the Nuralite specification package. All drawings are subject to copyright. Unauthorized use is prohibited. © Nuralite Waterproofing Ltd  
0800 - NURALITE (687254) www.nuralite.co.nz

PRODUCT/SYSTEM:	<b>NURAPLY 3PT &amp; 3PTM TANKING</b>		
DETAIL:	PILE HEAD		
SCALE: NTS	DATE: <b>SEP 2018</b>	PREVIOUS DWG no: -	REVISION: 1 DWG no: <b>TCP-.H2</b>

This drawing is indicative only and not for construction. This detail depicts Nuralite products and components for correct use as per the installation manual. All other elements are typical only - refer to the designer. Always refer to original colour details when printing.

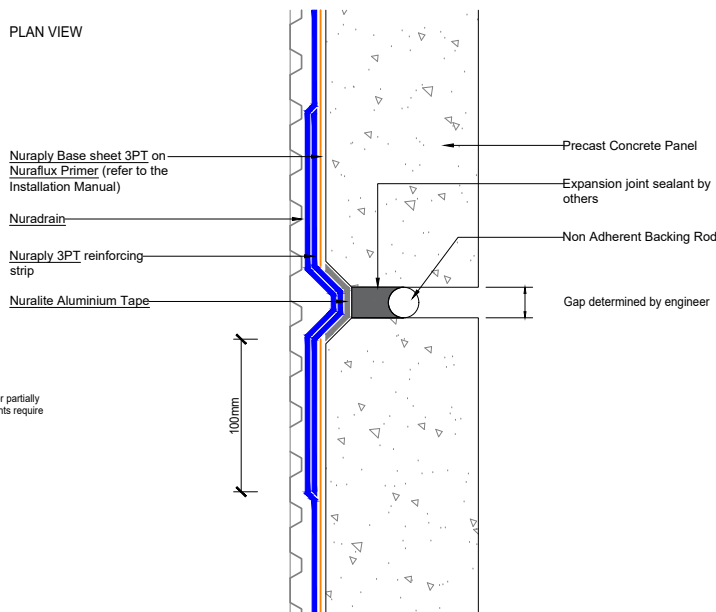

Note:  
For waterproofing the lower storey of a building wholly or partially below ground. Buildings with deep multi-storey basements require specialised, bespoke, designs.



All Nuralite products/systems to be installed by an authorized Nuralite applicator and in accordance with Nuralite published instruction. Product data sheets should be consulted at all times. This drawing is a guide and is not for construction. This detail drawing is to be used only as part of the Nuralite specification package. All drawings are subject to copyright. Unauthorized use is prohibited. © Nuralite Waterproofing Ltd  
0800 - NURALITE (687254) www.nuralite.co.nz

PRODUCT/SYSTEM:	<b>NURAPLY 3PT &amp; 3PTM TANKING</b>		
DETAIL:	PRECAST PANEL - MINOR EXPANSION JOINT/TANKING		
SCALE: NTS	DATE: <b>SEP 2018</b>	PREVIOUS DWG no: -	REVISION: 1 DWG no: <b>TCP-.I1</b>

This drawing is indicative only and not for construction. This detail depicts Nuralite products and components for correct use as per the installation manual. All other elements are typical only - refer to the designer. Always refer to original colour details when printing.

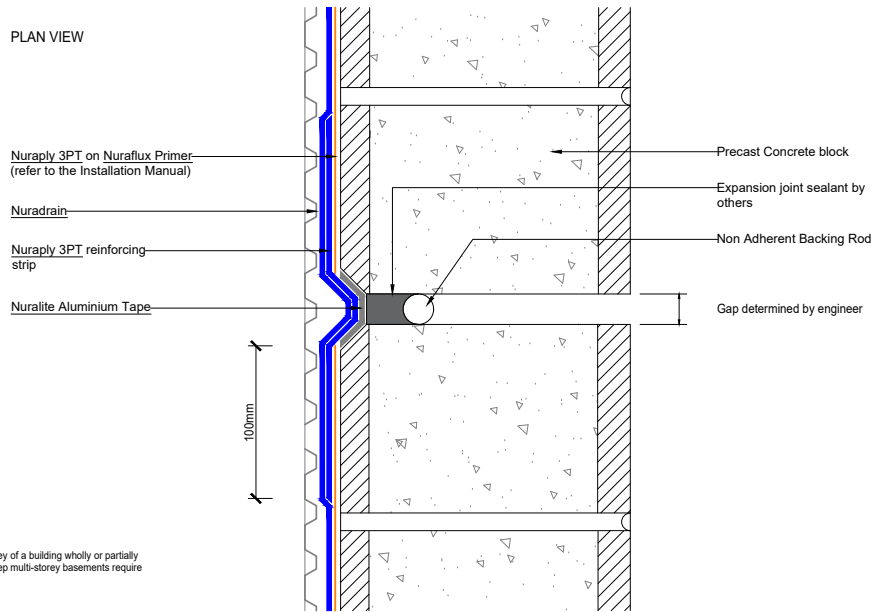

**Note:**  
For waterproofing the lower storey of a building wholly or partially below ground. Buildings with deep multi-storey basements require specialised, bespoke, designs.



All Nuralite products/systems to be installed by an authorized Nuralite applicator and in accordance with Nuralite published instruction. Product data sheets should be consulted at all times. This drawing is a guide and is not for construction. This detail drawing is to be used only as part of the Nuralite specification package. All drawings are subject to copyright. Unauthorized use is prohibited. © Nuralite Waterproofing Ltd  
0800 - NURALITE (687254) www.nuralite.co.nz

PRODUCT/SYSTEM:	<b>NURAPLY 3PT &amp; 3PTM TANKING</b>		
DETAIL:	BLOCK WALL - MINOR EXPANSION JOINT/TANKING		
SCALE: NTS	DATE: <b>SEP 2018</b>	PREVIOUS DWG no: -	REVISION: <b>1</b> DWG no: <b>TCP-.I2</b>

This drawing is indicative only and not for construction. This detail depicts Nuralite products and components for correct use as per the installation manual. All other elements are typical only - refer to the designer. Always refer to original colour details when printing.

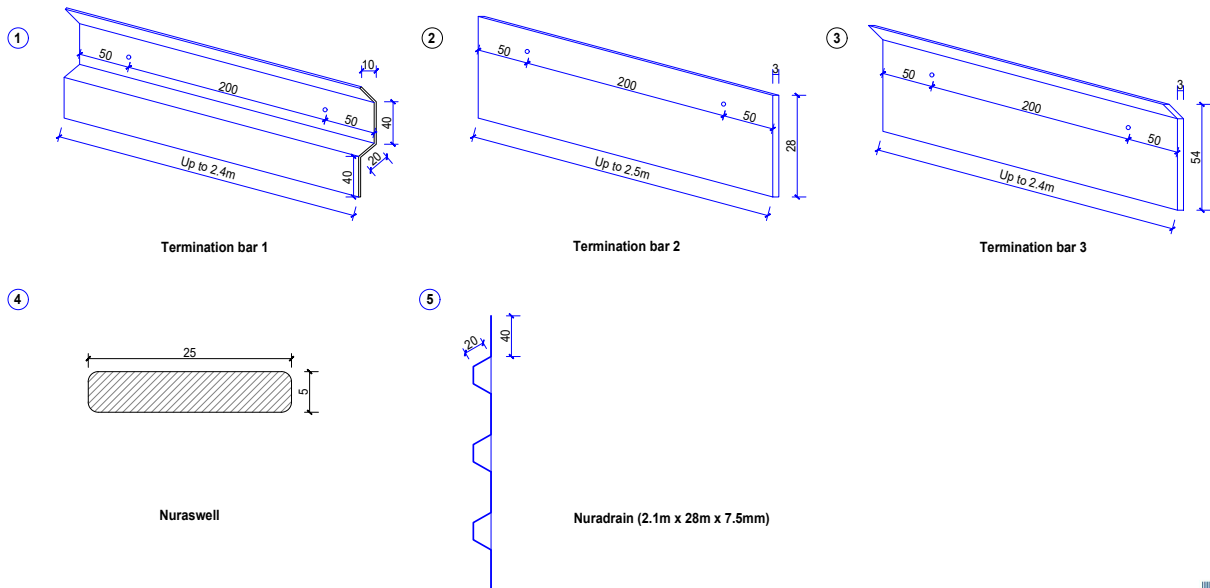

All Nuralite products/systems to be installed by an authorized Nuralite applicator and in accordance with Nuralite published instruction. Product data sheets should be consulted at all times. This drawing is a guide and is not for construction. This detail drawing is to be used only as part of the Nuralite specification package. All drawings are subject to copyright. Unauthorized use is prohibited. © Nuralite Waterproofing Ltd  
0800 - NURALITE (687254) www.nuralite.co.nz

PRODUCT/SYSTEM:	<b>NURAPLY 3PG &amp; 3PTM TANKING</b>		
DETAIL:	ASSESSORY PAGE		
SCALE: NTS	DATE: <b>SEP 2018</b>	PREVIOUS DWG no: -	REVISION: <b>1</b> DWG no: -

This drawing is indicative only and not for construction. This detail depicts Nuralite products and components for correct use as per the installation manual. All other elements are typical only - refer to the designer. Always refer to original colour details when printing.

**Note:**  
For waterproofing the lower storey of a building wholly or partially below ground. Buildings with deep multi-storey basements require specialised, bespoke, designs.

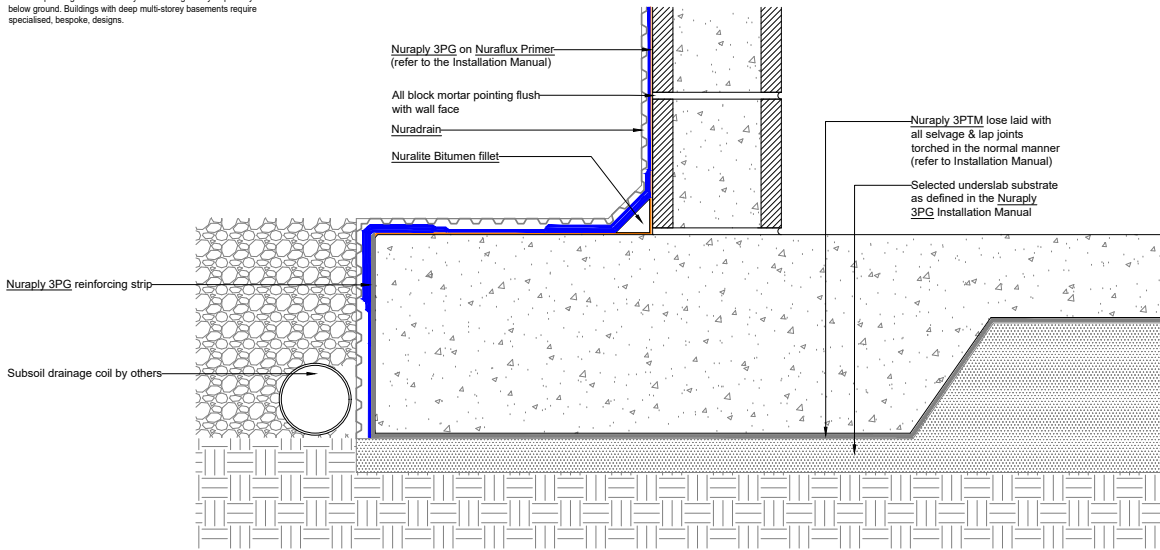

All Nuralite products/systems to be installed by an authorized Nuralite applicator and in accordance with Nuralite published instruction. Product data sheets should be consulted at all times. This drawing is a guide and is not for construction. This detail drawing is to be used only as part of the Nuralite specification package. All drawings are subject to copyright. Unauthorized use is prohibited. © Nuralite Waterproofing Ltd  
0800 - NURALITE (687254) www.nuralite.co.nz

PRODUCT/SYSTEM:	<b>NURAPLY 3PG &amp; 3PTM TANKING</b>		
DETAIL:	TOE DETAIL		
SCALE: NTS	DATE: <b>SEP 2018</b>	PREVIOUS DWG no: -	REVISION: <b>1</b> DWG no: <b>TCP-A1</b>

This drawing is indicative only and not for construction. This detail depicts Nuralite products and components for correct use as per the installation manual. All other elements are typical only - refer to the designer. Always refer to original colour details when printing.

**Note:**  
For waterproofing the lower storey of a building wholly or partially below ground. Buildings with deep multi-storey basements require specialised, bespoke, designs.

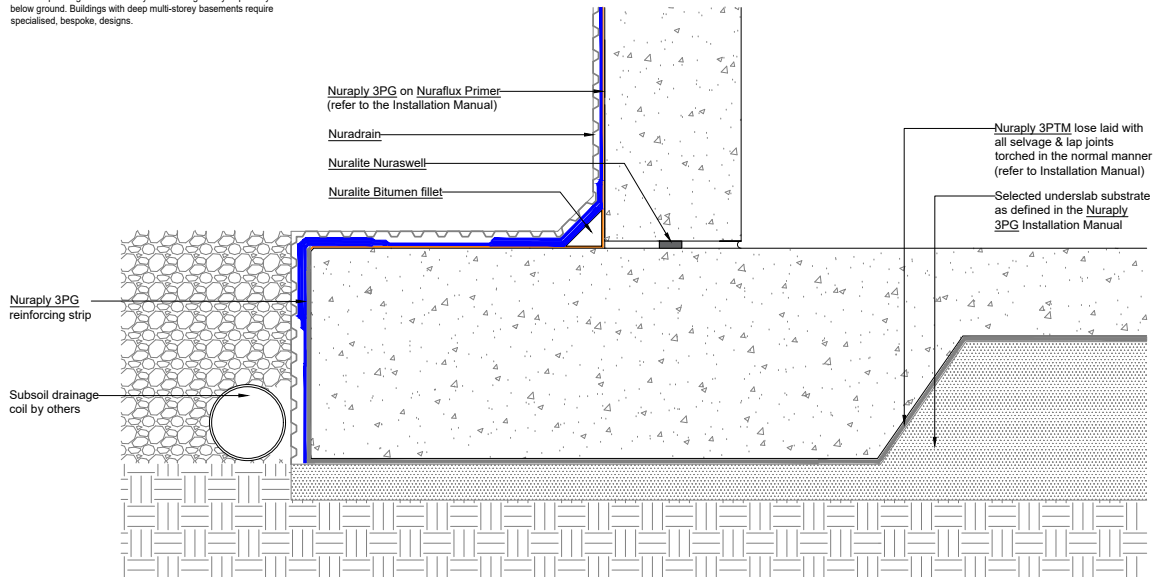

All Nuralite products/systems to be installed by an authorized Nuralite applicator and in accordance with Nuralite published instruction. Product data sheets should be consulted at all times. This drawing is a guide and is not for construction. This detail drawing is to be used only as part of the Nuralite specification package. All drawings are subject to copyright. Unauthorized use is prohibited. © Nuralite Waterproofing Ltd  
0800 - NURALITE (687254) www.nuralite.co.nz

PRODUCT/SYSTEM:	<b>NURAPLY 3PG &amp; 3PTM TANKING</b>		
DETAIL:	PRECAST TO TOE DETAIL		
SCALE: NTS	DATE: <b>SEP 2018</b>	PREVIOUS DWG no: -	REVISION: <b>1</b> DWG no: <b>TCP-A2</b>

This drawing is indicative only and not for construction. This detail depicts Nuralite products and components for correct use as per the installation manual. All other elements are typical only - refer to the designer. Always refer to original colour details when printing.

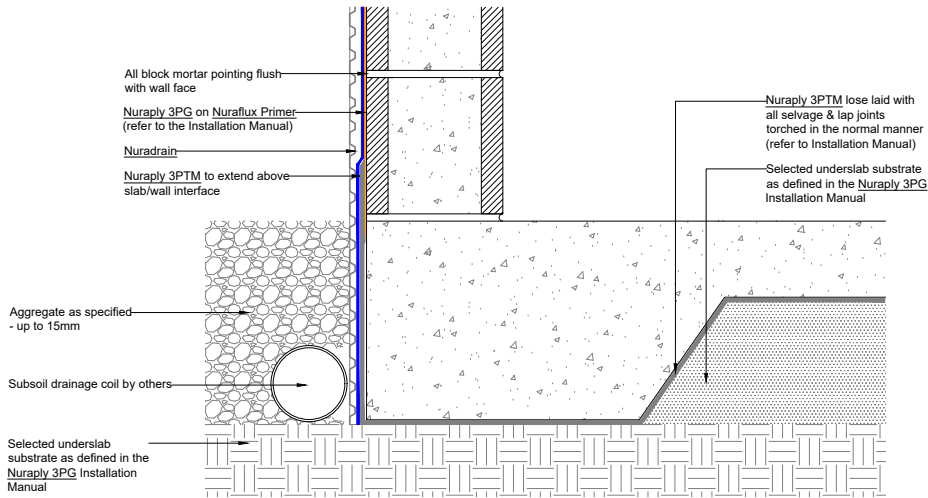

**Note:**  
For waterproofing the lower storey of a building wholly or partially below ground. Buildings with deep multi-storey basements require specialised, bespoke, designs.



All Nuralite products/systems to be installed by an authorized Nuralite applicator and in accordance with Nuralite published instruction. Product data sheets should be consulted at all times. This drawing is a guide and is not for construction. This detail drawing is to be used only as part of the Nuralite specification package. All drawings are subject to copyright. Unauthorized use is prohibited. © Nuralite Waterproofing Ltd  
0800 - NURALITE (687254) www.nuralite.co.nz

PRODUCT/SYSTEM:	<b>NURAPLY 3PG &amp; 3PTM TANKING</b>		
DETAIL:	BASEMENT FOOTING		
SCALE: NTS	DATE: <b>SEP 2018</b>	PREVIOUS DWG no: -	REVISION: 1 DWG no: <b>TCP-.B1</b>

This drawing is indicative only and not for construction. This detail depicts Nuralite products and components for correct use as per the installation manual. All other elements are typical only - refer to the designer. Always refer to original colour details when printing.

**Note:**  
Bond the PIR with Selleys Water Based Kwik Grip Gel. Tape any exposed edges of PIR with 150mm foil tape before installing. Tape all PIR joints with 48mm foil tape once installed and before coating with Nuracoat BG.

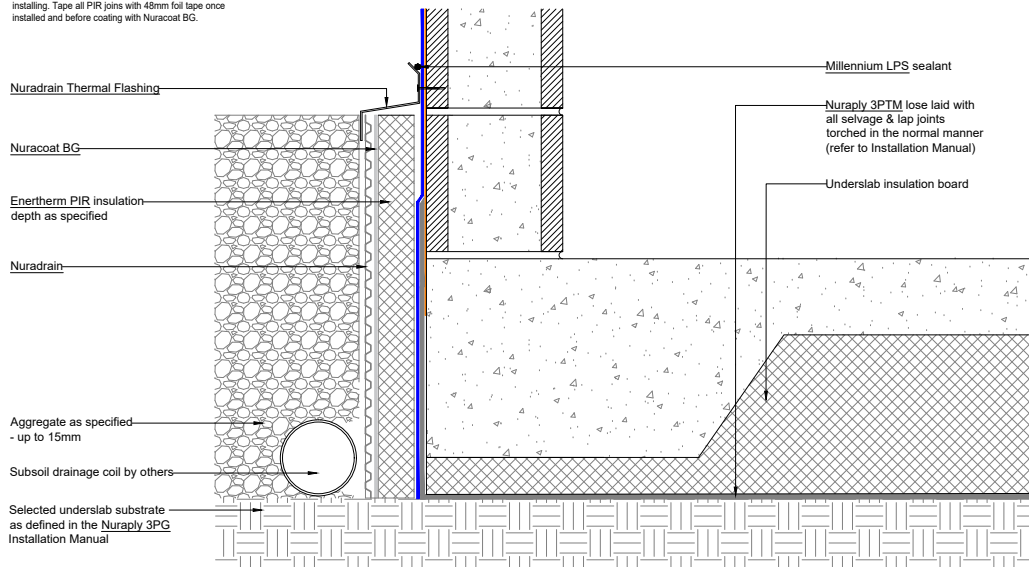

**Note:**  
For waterproofing the lower storey of a building wholly or partially below ground. Buildings with deep multi-storey basements require specialised, bespoke, designs.



All Nuralite products/systems to be installed by an authorized Nuralite applicator and in accordance with Nuralite published instruction. Product data sheets should be consulted at all times. This drawing is a guide and is not for construction. This detail drawing is to be used only as part of the Nuralite specification package. All drawings are subject to copyright. Unauthorized use is prohibited. © Nuralite Waterproofing Ltd  
0800 - NURALITE (687254) www.nuralite.co.nz

PRODUCT/SYSTEM:	<b>NURAPLY 3PG &amp; 3PTM TANKING</b>		
DETAIL:	BASEMENT FOOTING WITH FULL INSULATION		
SCALE: NTS	DATE: <b>SEP 2018</b>	PREVIOUS DWG no: -	REVISION: 1 DWG no: <b>TCP-.B2</b>

This drawing is indicative only and not for construction. This detail depicts Nuralite products and components for correct use as per the installation manual. All other elements are typical only - refer to the designer. Always refer to original colour details when printing.

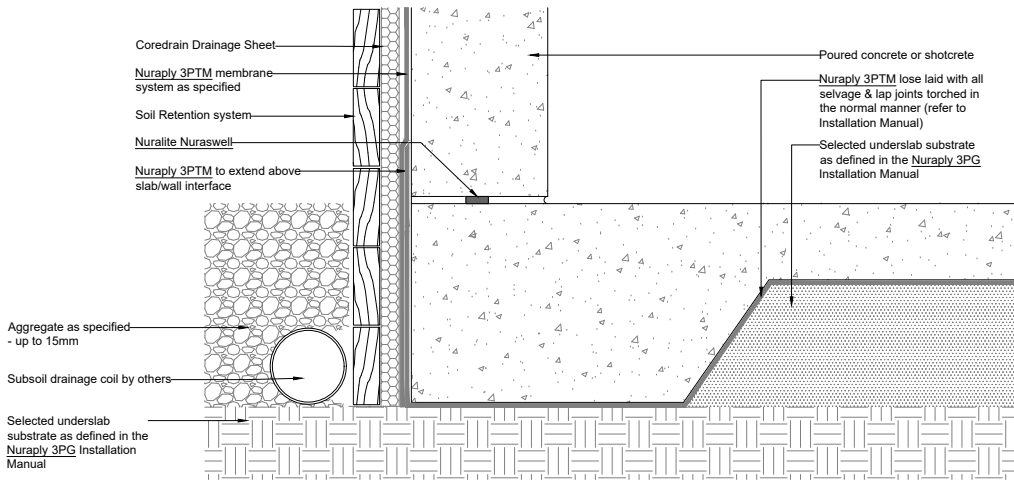

**Note:**  
For waterproofing the lower storey of a building wholly or partially below ground. Buildings with deep multi-storey basements require specialised, bespoke, designs.



All Nuralite products/systems to be installed by an authorized Nuralite applicator and in accordance with Nuralite published instruction. Product data sheets should be consulted at all times. This drawing is a guide and is not for construction. This detail drawing is to be used only as part of the Nuralite specification package. All drawings are subject to copyright. Unauthorized use is prohibited. © Nuralite Waterproofing Ltd  
0800 - NURALITE (687254) www.nuralite.co.nz

PRODUCT/SYSTEM:	<b>NURAPLY 3PG &amp; 3PTM TANKING</b>		
DETAIL:	BLINDSIDE WALL TO SLAB TIE IN		
SCALE: NTS	DATE: <b>SEP 2018</b>	PREVIOUS DWG no: -	REVISION: <b>1</b> DWG no: <b>TCP-.B3</b>



This drawing is indicative only and not for construction. This detail depicts Nuralite products and components for correct use as per the installation manual. All other elements are typical only - refer to the designer. Always refer to original colour details when printing.

PLAN VIEW

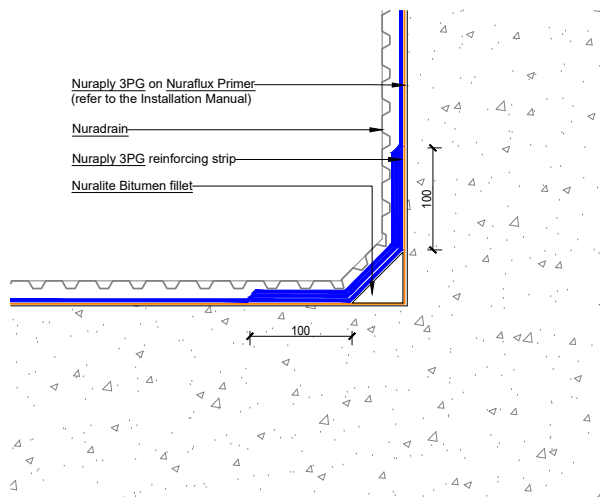

**Note:**  
For waterproofing the lower storey of a building wholly or partially below ground. Buildings with deep multi-storey basements require specialised, bespoke, designs.



All Nuralite products/systems to be installed by an authorized Nuralite applicator and in accordance with Nuralite published instruction. Product data sheets should be consulted at all times. This drawing is a guide and is not for construction. This detail drawing is to be used only as part of the Nuralite specification package. All drawings are subject to copyright. Unauthorized use is prohibited. © Nuralite Waterproofing Ltd  
0800 - NURALITE (687254) www.nuralite.co.nz

PRODUCT/SYSTEM:	<b>NURAPLY 3PG &amp; 3PTM TANKING</b>		
DETAIL:	INTERNAL CORNER		
SCALE: NTS	DATE: <b>SEP 2018</b>	PREVIOUS DWG no: -	REVISION: <b>1</b> DWG no: <b>TCP-.C1</b>





This drawing is indicative only and not for construction. This detail depicts Nuralite products and components for correct use as per the installation manual. All other elements are typical only - refer to the designer. Always refer to original colour details when printing.

PLAN VIEW

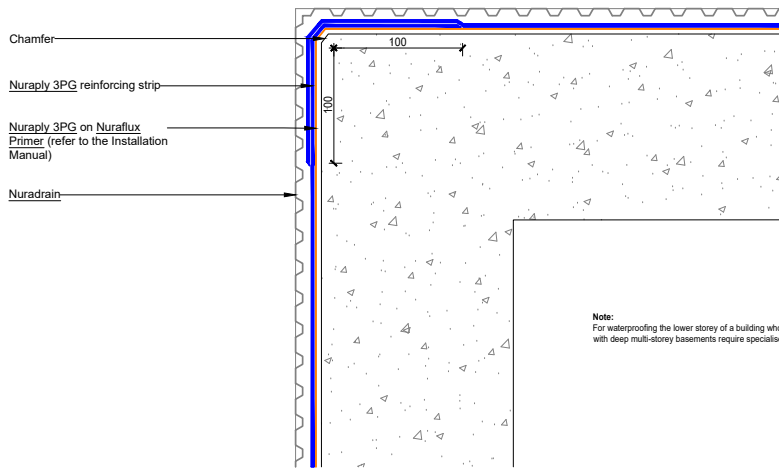

All Nuralite products/systems to be installed by an authorized Nuralite applicator and in accordance with Nuralite published instruction. Product data sheets should be consulted at all times. This drawing is a guide and is not for construction. This detail drawing is to be used only as part of the Nuralite specification package. All drawings are subject to copyright. Unauthorized use is prohibited. © Nuralite Waterproofing Ltd  
0800 - NURALITE (687254) www.nuralite.co.nz

PRODUCT/SYSTEM:	<b>NURAPLY 3PG &amp; 3PTM TANKING</b>		
DETAIL:	EXTERNAL CORNER		
SCALE: NTS	DATE: <b>SEP 2018</b>	PREVIOUS DWG no: -	REVISION: <b>1</b> DWG no: <b>TCP-D1</b>

This drawing is indicative only and not for construction. This detail depicts Nuralite products and components for correct use as per the installation manual. All other elements are typical only - refer to the designer. Always refer to original colour details when printing.

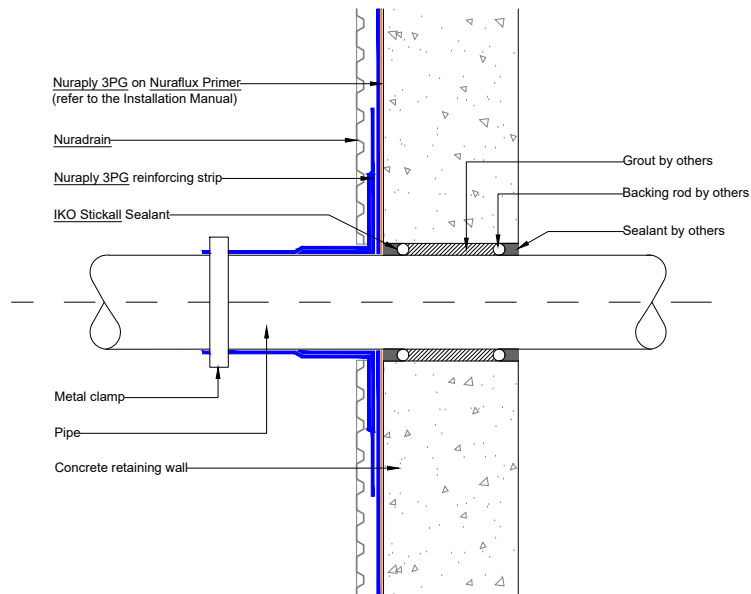

All Nuralite products/systems to be installed by an authorized Nuralite applicator and in accordance with Nuralite published instruction. Product data sheets should be consulted at all times. This drawing is a guide and is not for construction. This detail drawing is to be used only as part of the Nuralite specification package. All drawings are subject to copyright. Unauthorized use is prohibited. © Nuralite Waterproofing Ltd  
0800 - NURALITE (687254) www.nuralite.co.nz

PRODUCT/SYSTEM:	<b>NURAPLY 3PG &amp; 3PTM TANKING</b>		
DETAIL:	CONCRETE WALL PENETRATION		
SCALE: NTS	DATE: <b>SEP 2018</b>	PREVIOUS DWG no: -	REVISION: <b>1</b> DWG no: <b>TCP-E1</b>



This drawing is indicative only and not for construction. This detail depicts Nuralite products and components for correct use as per the installation manual. All other elements are typical only - refer to the designer. Always refer to original colour details when printing.

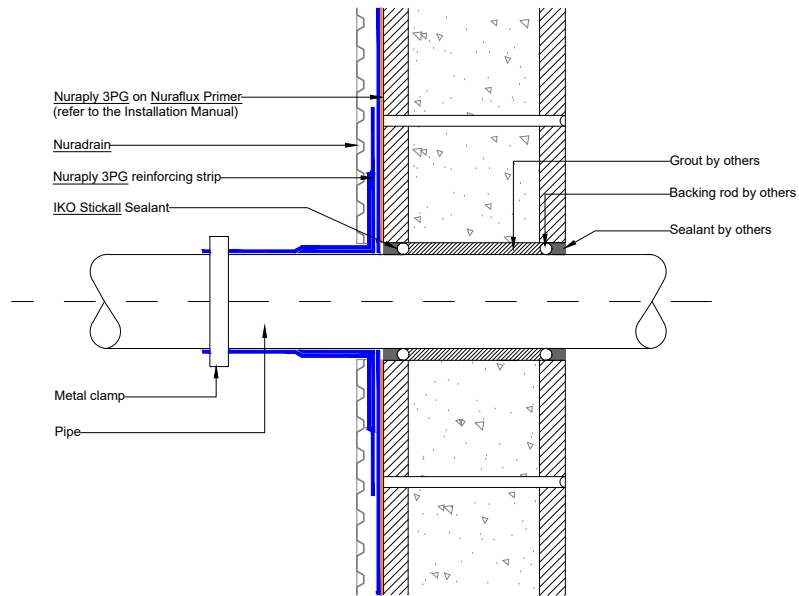

All Nuralite products/systems to be installed by an authorized Nuralite applicator and in accordance with Nuralite published instruction. Product data sheets should be consulted at all times. This drawing is a guide and is not for construction. This detail drawing is to be used only as part of the Nuralite specification package. All drawings are subject to copyright. Unauthorized use is prohibited. © Nuralite Waterproofing Ltd  
0800 - NURALITE (687254) www.nuralite.co.nz

PRODUCT/SYSTEM:	<b>NURAPLY 3PG &amp; 3PTM TANKING</b>		
DETAIL:	BLOCK WALL PENETRATION		
SCALE: NTS	DATE: <b>SEP 2018</b>	PREVIOUS DWG no: -	REVISION: <b>1</b> DWG no: <b>TCP-.E2</b>

This drawing is indicative only and not for construction. This detail depicts Nuralite products and components for correct use as per the installation manual. All other elements are typical only - refer to the designer. Always refer to original colour details when printing.

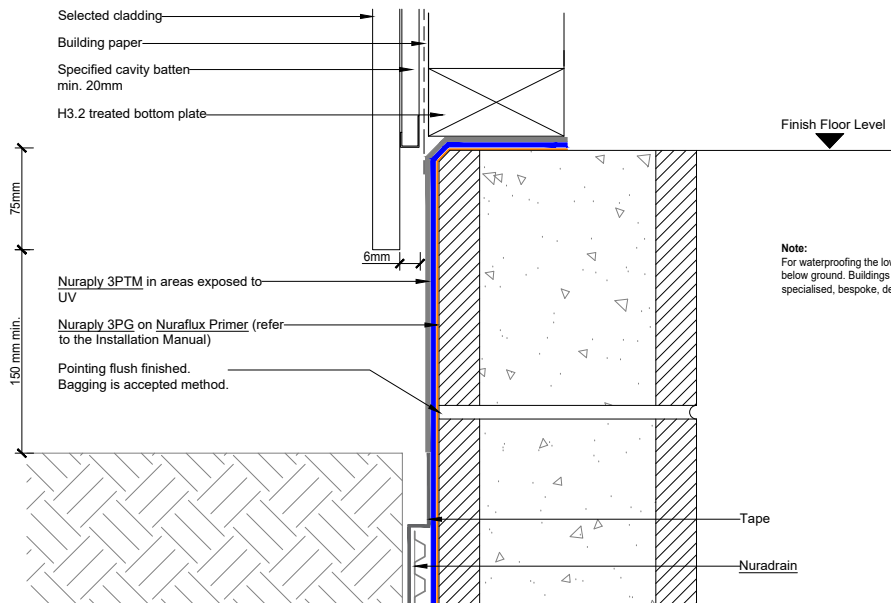

All Nuralite products/systems to be installed by an authorized Nuralite applicator and in accordance with Nuralite published instruction. Product data sheets should be consulted at all times. This drawing is a guide and is not for construction. This detail drawing is to be used only as part of the Nuralite specification package. All drawings are subject to copyright. Unauthorized use is prohibited. © Nuralite Waterproofing Ltd  
0800 - NURALITE (687254) www.nuralite.co.nz

PRODUCT/SYSTEM:	<b>NURAPLY 3PG &amp; 3PTM TANKING</b>		
DETAIL:	TERMINATION UNDER BOTTOM PLATE		
SCALE: NTS	DATE: <b>SEP 2018</b>	PREVIOUS DWG no: -	REVISION: <b>1</b> DWG no: <b>TCP-.F1</b>

This drawing is indicative only and not for construction. This detail depicts Nuralite products and components for correct use as per the installation manual. All other elements are typical only - refer to the designer. Always refer to original colour details when printing.

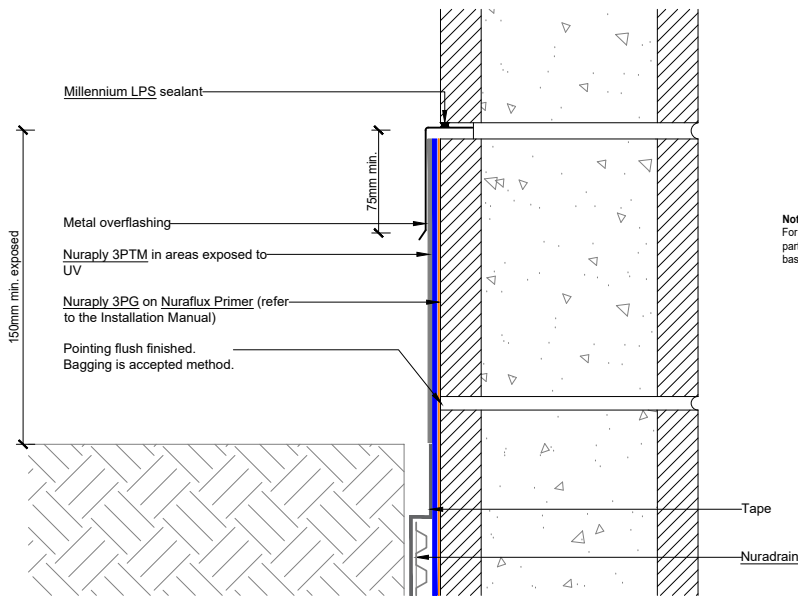

**Note:**  
For waterproofing the lower storey of a building wholly or partially below ground. Buildings with deep multi-storey basements require specialised, bespoke, designs.



All Nuralite products/systems to be installed by an authorized Nuralite applicator and in accordance with Nuralite published instruction. Product data sheets should be consulted at all times. This drawing is a guide and is not for construction. This detail drawing is to be used only as part of the Nuralite specification package. All drawings are subject to copyright. Unauthorized use is prohibited. © Nuralite Waterproofing Ltd  
0800 - NURALITE (687254) www.nuralite.co.nz

PRODUCT/SYSTEM:	<b>NURAPLY 3PG &amp; 3PTM TANKING</b>		
DETAIL:	TERMINATION INTO CHASE		
SCALE: NTS	DATE: <b>SEP 2018</b>	PREVIOUS DWG no: -	REVISION: <b>1</b> DWG no: <b>TCP-.F2</b>

This drawing is indicative only and not for construction. This detail depicts Nuralite products and components for correct use as per the installation manual. All other elements are typical only - refer to the designer. Always refer to original colour details when printing.

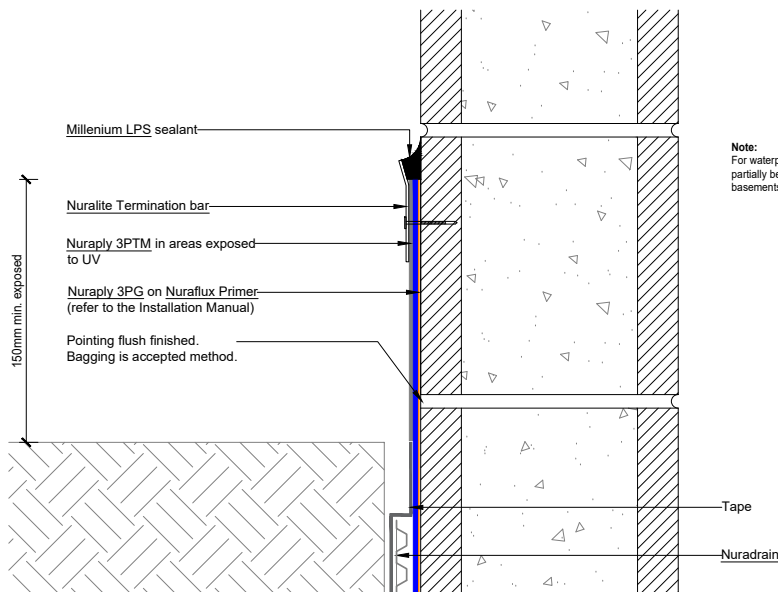

**Note:**  
For waterproofing the lower storey of a building wholly or partially below ground. Buildings with deep multi-storey basements require specialised, bespoke, designs.



All Nuralite products/systems to be installed by an authorized Nuralite applicator and in accordance with Nuralite published instruction. Product data sheets should be consulted at all times. This drawing is a guide and is not for construction. This detail drawing is to be used only as part of the Nuralite specification package. All drawings are subject to copyright. Unauthorized use is prohibited. © Nuralite Waterproofing Ltd  
0800 - NURALITE (687254) www.nuralite.co.nz

PRODUCT/SYSTEM:	<b>NURAPLY 3PG &amp; 3PTM TANKING</b>		
DETAIL:	TERMINATION USING TERMINATION BAR		
SCALE: NTS	DATE: <b>SEP 2018</b>	PREVIOUS DWG no: -	REVISION: <b>1</b> DWG no: <b>TCP-.F3</b>

This drawing is indicative only and not for construction. This detail depicts Nuralite products and components for correct use as per the installation manual. All other elements are typical only - refer to the designer. Always refer to original colour details when printing.

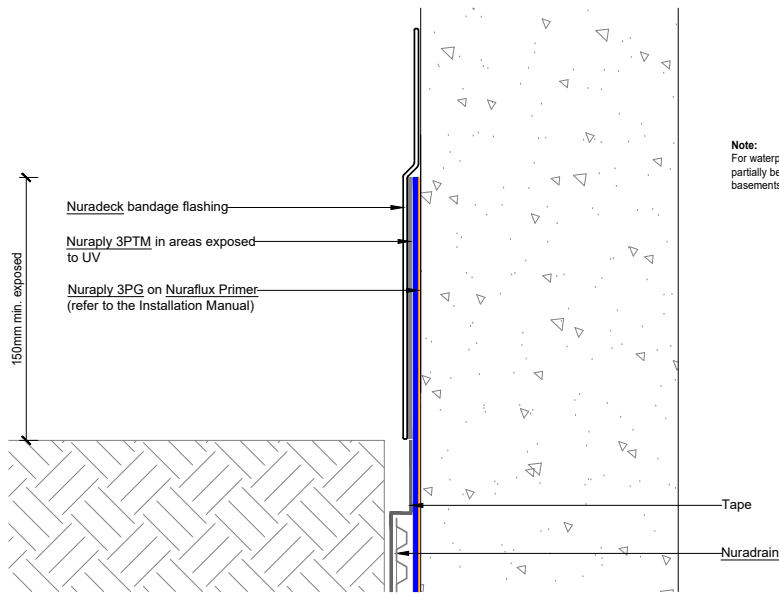

**Note:**  
For waterproofing the lower storey of a building wholly or partially below ground. Buildings with deep multi-storey basements require specialised, bespoke, designs.



All Nuralite products/systems to be installed by an authorized Nuralite applicator and in accordance with Nuralite published instruction. Product data sheets should be consulted at all times. This drawing is a guide and is not for construction. This detail drawing is to be used only as part of the Nuralite specification package. All drawings are subject to copyright. Unauthorized use is prohibited. © Nuralite Waterproofing Ltd  
0800 - NURALITE (687254) www.nuralite.co.nz

PRODUCT/SYSTEM:	<b>NURAPLY 3PG &amp; 3PTM TANKING</b>		
DETAIL:	TERMINATION USING NURADECK BANDAGE FLASHING		
SCALE: NTS	DATE: <b>SEP 2018</b>	PREVIOUS DWG no: -	REVISION: <b>1</b> DWG no: <b>TCP-.F4</b>

This drawing is indicative only and not for construction. This detail depicts Nuralite products and components for correct use as per the installation manual. All other elements are typical only - refer to the designer. Always refer to original colour details when printing.

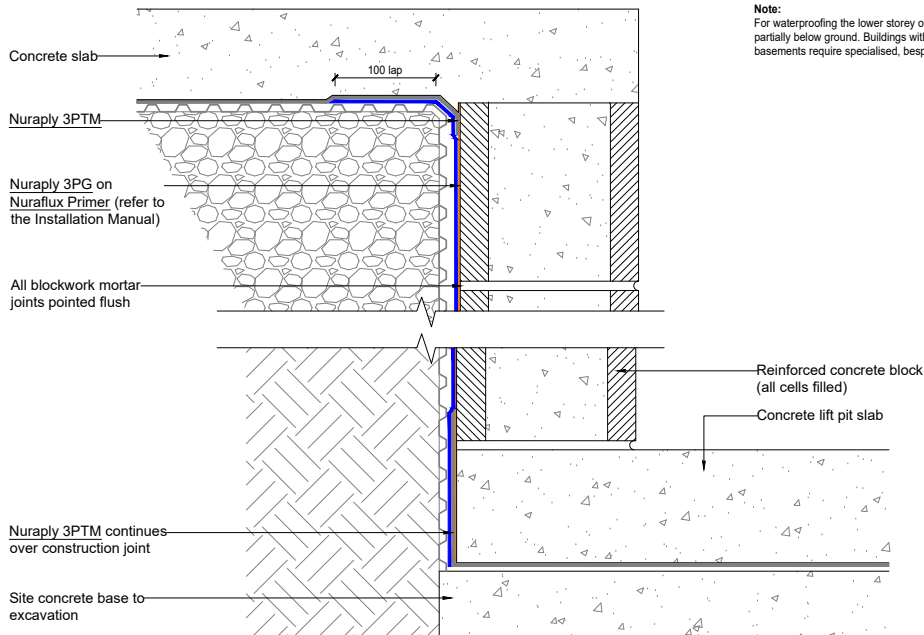

**Note:**  
For waterproofing the lower storey of a building wholly or partially below ground. Buildings with deep multi-storey basements require specialised, bespoke, designs.



All Nuralite products/systems to be installed by an authorized Nuralite applicator and in accordance with Nuralite published instruction. Product data sheets should be consulted at all times. This drawing is a guide and is not for construction. This detail drawing is to be used only as part of the Nuralite specification package. All drawings are subject to copyright. Unauthorized use is prohibited. © Nuralite Waterproofing Ltd  
0800 - NURALITE (687254) www.nuralite.co.nz

PRODUCT/SYSTEM:	<b>NURAPLY 3PG &amp; 3PTM TANKING</b>		
DETAIL:	LIFT PIT		
SCALE: NTS	DATE: <b>SEP 2018</b>	PREVIOUS DWG no: -	REVISION: <b>1</b> DWG no: <b>TCP-.G1</b>

This drawing is indicative only and not for construction. This detail depicts Nuralite products and components for correct use as per the installation manual. All other elements are typical only - refer to the designer. Always refer to original colour details when printing.

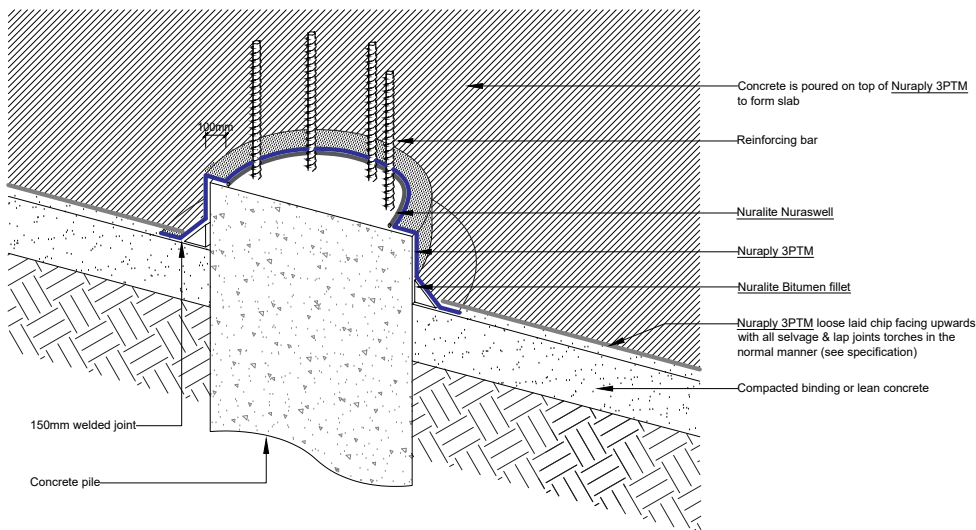

ISOMETRIC



All Nuralite products/systems to be installed by an authorized Nuralite applicator and in accordance with Nuralite published instruction. Product data sheets should be consulted at all times. This drawing is a guide and is not for construction. This detail drawing is to be used only as part of the Nuralite specification package. All drawings are subject to copyright. Unauthorized use is prohibited. © Nuralite Waterproofing Ltd  
0800 - NURALITE (687254) www.nuralite.co.nz

PRODUCT/SYSTEM:	<b>NURAPLY 3PG &amp; 3PTM TANKING</b>		
DETAIL:	PILE HEAD DETAIL		
SCALE: NTS	DATE: <b>SEP 2018</b>	PREVIOUS DWG no: -	REVISION: <b>1</b> DWG no: <b>TCP.H1 iso</b>

This drawing is indicative only and not for construction. This detail depicts Nuralite products and components for correct use as per the installation manual. All other elements are typical only - refer to the designer. Always refer to original colour details when printing.

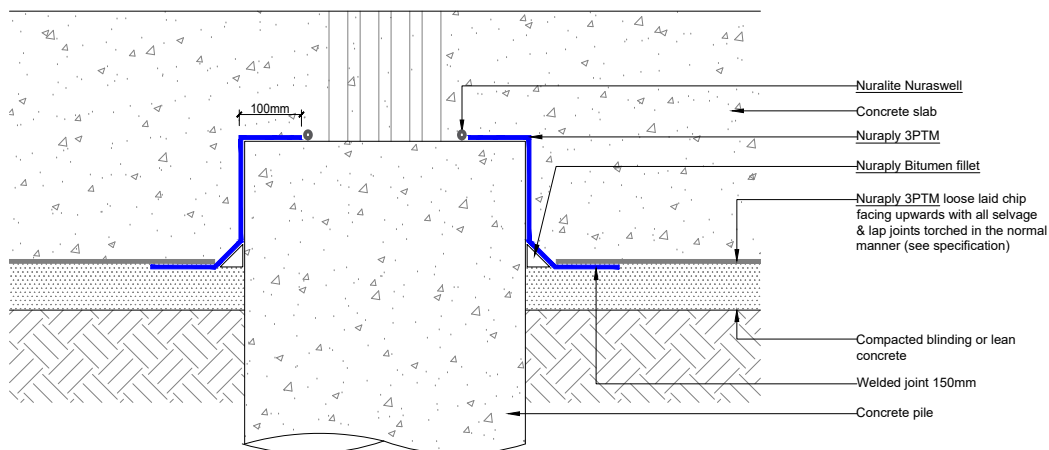

Note:  
Tanking under the slab must be considered when slab FFL (finished floor level) is 300mm below outside FFL.



All Nuralite products/systems to be installed by an authorized Nuralite applicator and in accordance with Nuralite published instruction. Product data sheets should be consulted at all times. This drawing is a guide and is not for construction. This detail drawing is to be used only as part of the Nuralite specification package. All drawings are subject to copyright. Unauthorized use is prohibited. © Nuralite Waterproofing Ltd  
0800 - NURALITE (687254) www.nuralite.co.nz

PRODUCT/SYSTEM:	<b>NURAPLY 3PG &amp; 3PTM TANKING</b>		
DETAIL:	PILE HEAD		
SCALE: NTS	DATE: <b>SEP 2018</b>	PREVIOUS DWG no: -	REVISION: <b>1</b> DWG no: <b>TCP-.H1</b>

This drawing is indicative only and not for construction. This detail depicts Nuralite products and components for correct use as per the installation manual. All other elements are typical only - refer to the designer. Always refer to original colour details when printing.

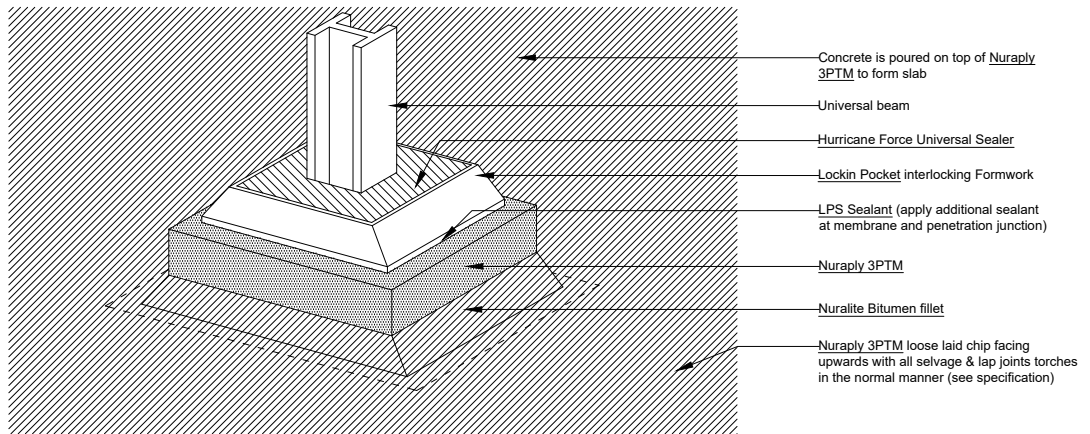

ISOMETRIC



All Nuralite products/systems to be installed by an authorized Nuralite applicator and in accordance with Nuralite published instruction. Product data sheets should be consulted at all times. This drawing is a guide and is not for construction. This detail drawing is to be used only as part of the Nuralite specification package. All drawings are subject to copyright. Unauthorized use is prohibited. © Nuralite Waterproofing Ltd  
0800 - NURALITE (687254) www.nuralite.co.nz

PRODUCT/SYSTEM:	<b>NURALITE 3PG &amp; 3PTM TANKING</b>		
DETAIL:	PILE HEAD DETAIL		
SCALE: NTS	DATE: <b>SEP 2018</b>	PREVIOUS DWG no: -	REVISION: <b>1</b> DWG no: <b>TCP.H2 iso</b>

This drawing is indicative only and not for construction. This detail depicts Nuralite products and components for correct use as per the installation manual. All other elements are typical only - refer to the designer. Always refer to original colour details when printing.

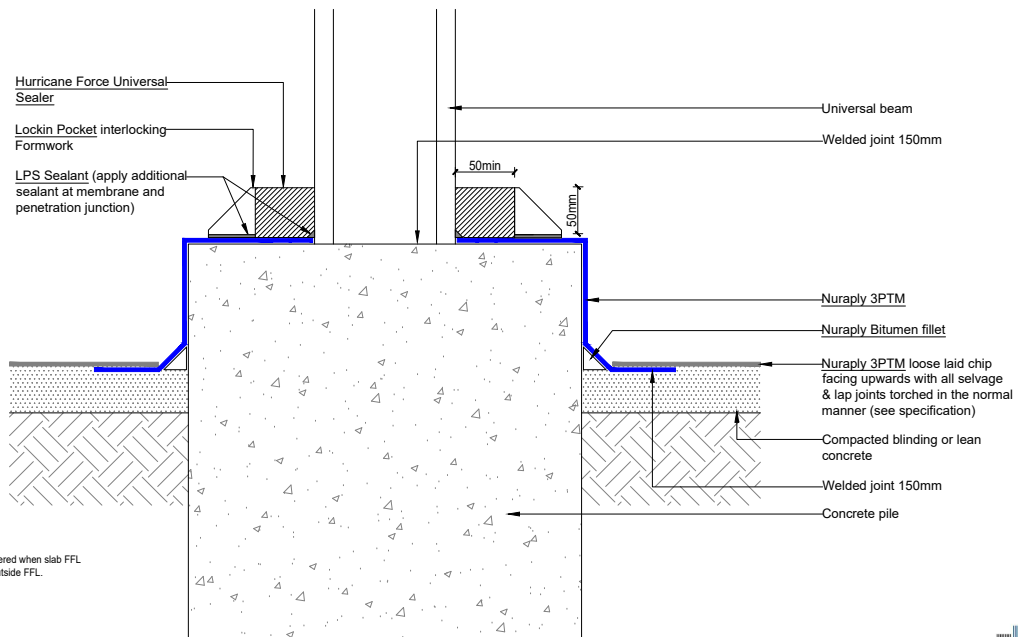

Note:  
Tanking under the slab must be considered when slab FFL (finished floor level) is 300mm below outside FFL.



All Nuralite products/systems to be installed by an authorized Nuralite applicator and in accordance with Nuralite published instruction. Product data sheets should be consulted at all times. This drawing is a guide and is not for construction. This detail drawing is to be used only as part of the Nuralite specification package. All drawings are subject to copyright. Unauthorized use is prohibited. © Nuralite Waterproofing Ltd  
0800 - NURALITE (687254) www.nuralite.co.nz

PRODUCT/SYSTEM:	<b>NURALITE 3PG &amp; 3PTM TANKING</b>		
DETAIL:	PILE HEAD		
SCALE: NTS	DATE: <b>SEP 2018</b>	PREVIOUS DWG no: -	REVISION: <b>1</b> DWG no: <b>TCP-.H2</b>

This drawing is indicative only and not for construction. This detail depicts Nuralite products and components for correct use as per the installation manual. All other elements are typical only - refer to the designer. Always refer to original colour details when printing.

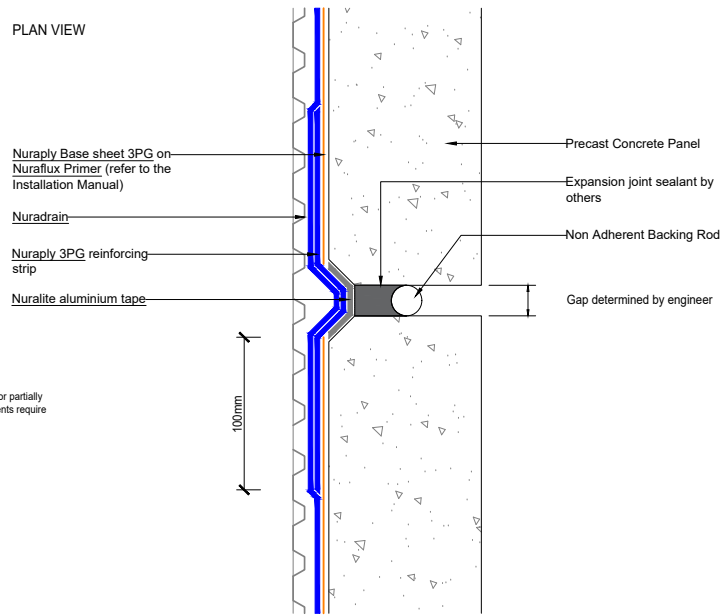

**Note:**  
For waterproofing the lower storey of a building wholly or partially below ground. Buildings with deep multi-storey basements require specialised, bespoke, designs.



All Nuralite products/systems to be installed by an authorized Nuralite applicator and in accordance with Nuralite published instruction. Product data sheets should be consulted at all times. This drawing is a guide and is not for construction. This detail drawing is to be used only as part of the Nuralite specification package. All drawings are subject to copyright. Unauthorized use is prohibited. © Nuralite Waterproofing Ltd  
0800 - NURALITE (687254) www.nuralite.co.nz

PRODUCT/SYSTEM:	<b>NURAPLY 3PG &amp; 3PTM TANKING</b>		
DETAIL:	PRECAST PANEL - MINOR EXPANSION JOINT/TANKING		
SCALE: NTS	DATE: <b>SEP 2018</b>	PREVIOUS DWG no: -	REVISION: <b>1</b> DWG no: <b>TCP-.11</b>

This drawing is indicative only and not for construction. This detail depicts Nuralite products and components for correct use as per the installation manual. All other elements are typical only - refer to the designer. Always refer to original colour details when printing.

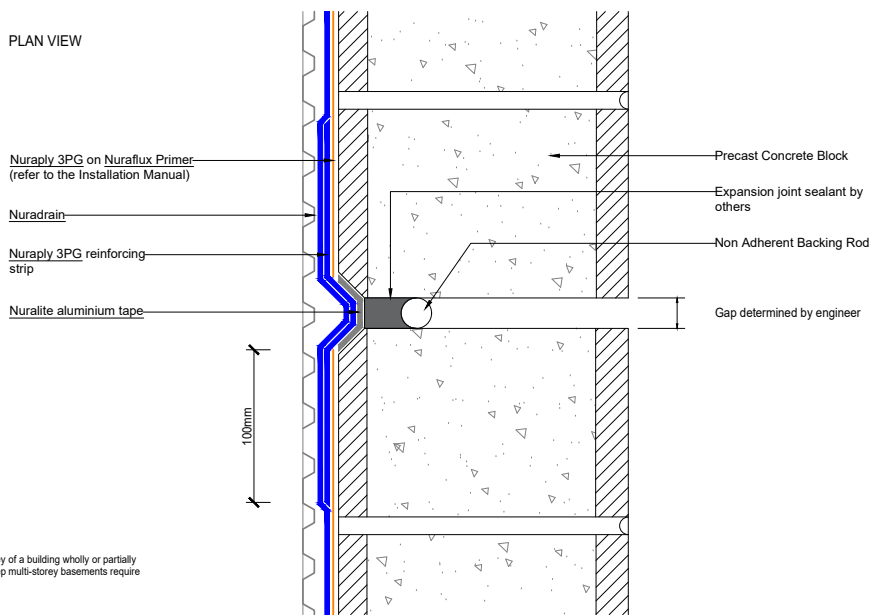

**Note:**  
For waterproofing the lower storey of a building wholly or partially below ground. Buildings with deep multi-storey basements require specialised, bespoke, designs.



All Nuralite products/systems to be installed by an authorized Nuralite applicator and in accordance with Nuralite published instruction. Product data sheets should be consulted at all times. This drawing is a guide and is not for construction. This detail drawing is to be used only as part of the Nuralite specification package. All drawings are subject to copyright. Unauthorized use is prohibited. © Nuralite Waterproofing Ltd  
0800 - NURALITE (687254) www.nuralite.co.nz

PRODUCT/SYSTEM:	<b>NURAPLY 3PG &amp; 3PTM TANKING</b>		
DETAIL:	BLOCK WALL - MINOR EXPANSION JOINT/TANKING		
SCALE: NTS	DATE: <b>SEP 2018</b>	PREVIOUS DWG no: -	REVISION: <b>1</b> DWG no: <b>TCP-.12</b>

This drawing is indicative only and not for construction. This detail depicts Nuralite products and components for correct use as per the installation manual. All other elements are typical only - refer to the designer. Always refer to original colour details when printing.

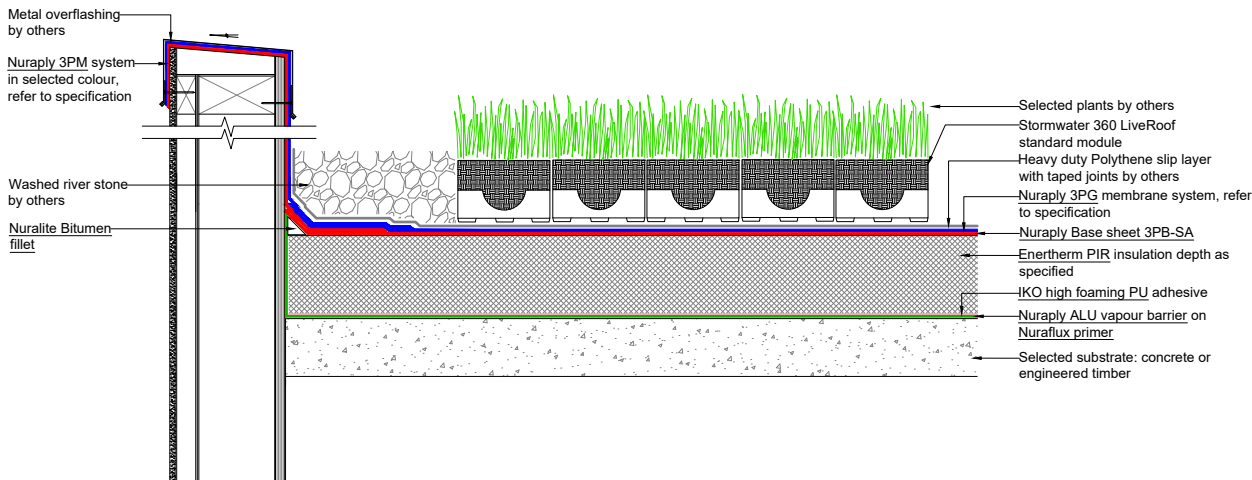

All Nuralite products/systems to be installed by an authorized Nuralite applicator and in accordance with Nuralite published instruction. Product data sheets should be consulted at all times. This drawing is a guide and is not for construction. This detail drawing is to be used only as part of the Nuralite specification package. All drawings are subject to copyright. Unauthorized use is prohibited. © Nuralite Waterproofing Ltd  
 0800 - NURALITE (687254) www.nuralite.co.nz

PRODUCT/SYSTEM:	<b>PROTECTED MEMBRANE GREEN ROOF</b>		
DETAIL:	UPSTAND		
SCALE:	NTS	DATE: <b>SEP 2018</b>	PREVIOUS DWG no: -
REVISION:	<b>1</b>	DWG no:	<b>GCP.C1</b>

This drawing is indicative only and not for construction. This detail depicts Nuralite products and components for correct use as per the installation manual. All other elements are typical only - refer to the designer. Always refer to original colour details when printing.

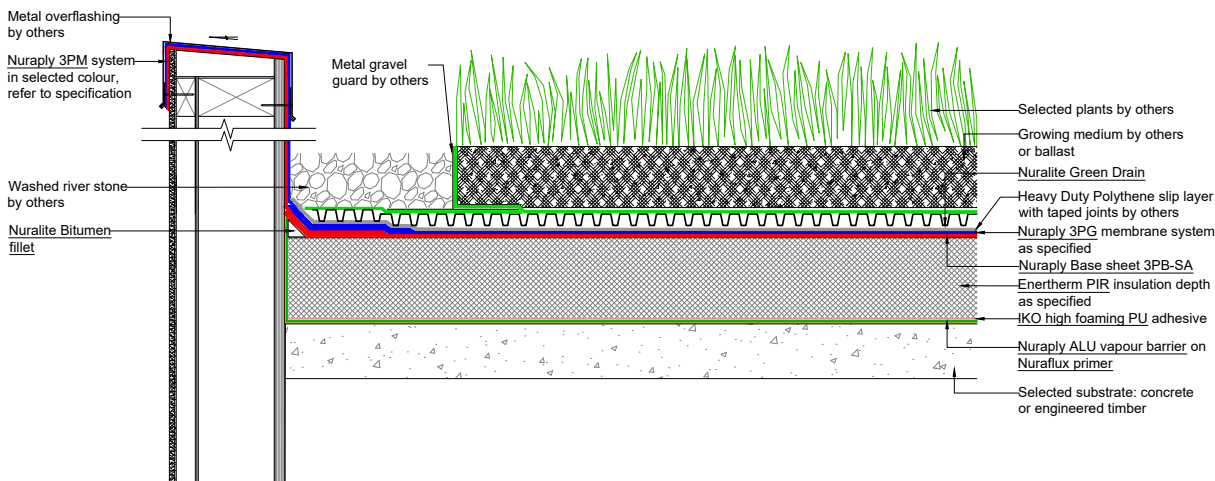

All Nuralite products/systems to be installed by an authorized Nuralite applicator and in accordance with Nuralite published instruction. Product data sheets should be consulted at all times. This drawing is a guide and is not for construction. This detail drawing is to be used only as part of the Nuralite specification package. All drawings are subject to copyright. Unauthorized use is prohibited. © Nuralite Waterproofing Ltd  
 0800 - NURALITE (687254) www.nuralite.co.nz

PRODUCT/SYSTEM:	<b>PROTECTED MEMBRANE GREEN ROOF</b>		
DETAIL:	UPSTAND		
SCALE:	NTS	DATE: <b>SEP 2018</b>	PREVIOUS DWG no: -
REVISION:	<b>1</b>	DWG no:	<b>GCP.C2</b>



This drawing is indicative only and not for construction. This detail depicts Nuralite products and components for correct use as per the installation manual. All other elements are typical only - refer to the designer. Always refer to original colour details when printing.

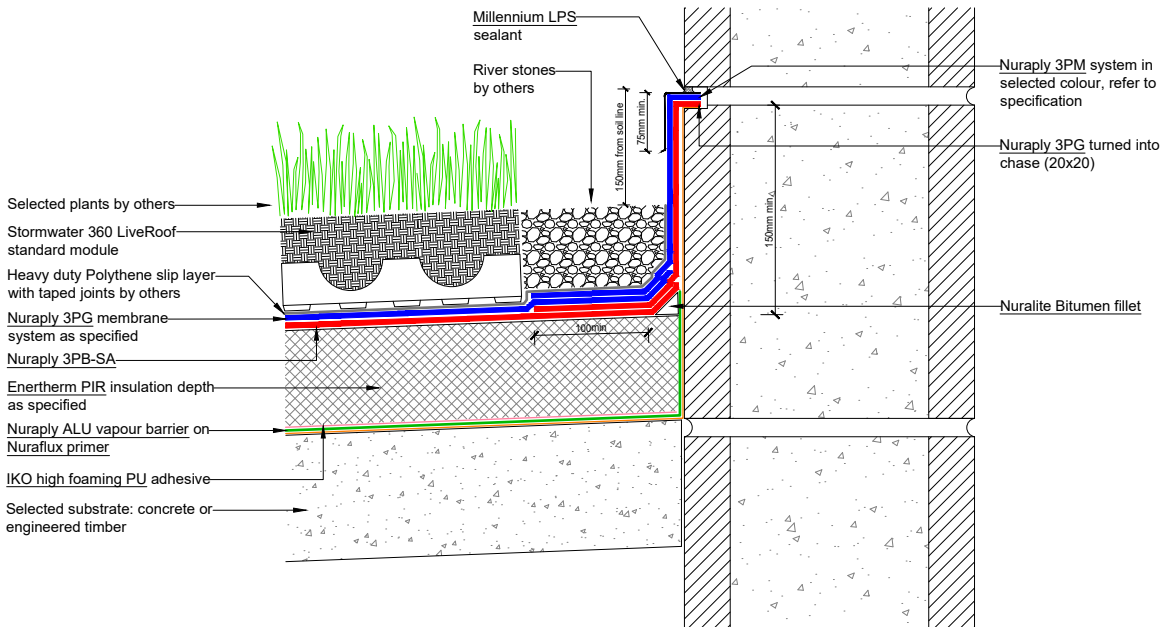

All Nuralite products/systems to be installed by an authorized Nuralite applicator and in accordance with Nuralite published instruction. Product data sheets should be consulted at all times. This drawing is a guide and is not for construction. This detail drawing is to be used only as part of the Nuralite specification package. All drawings are subject to copyright. Unauthorized use is prohibited. © Nuralite Waterproofing Ltd  
0800 - NURALITE (687254) www.nuralite.co.nz

PRODUCT/SYSTEM: **PROTECTED MEMBRANE GREEN ROOF**  
DETAIL: **WARM/GREEN ROOF - NURAPLY 3PM UPSTAND TERMINATION DETAIL**  
SCALE: **NTS** DATE: **SEP 2018** PREVIOUS DWG no: - REVISION: **1** DWG no: **GCP.D1**

This drawing is indicative only and not for construction. This detail depicts Nuralite products and components for correct use as per the installation manual. All other elements are typical only - refer to the designer. Always refer to original colour details when printing.

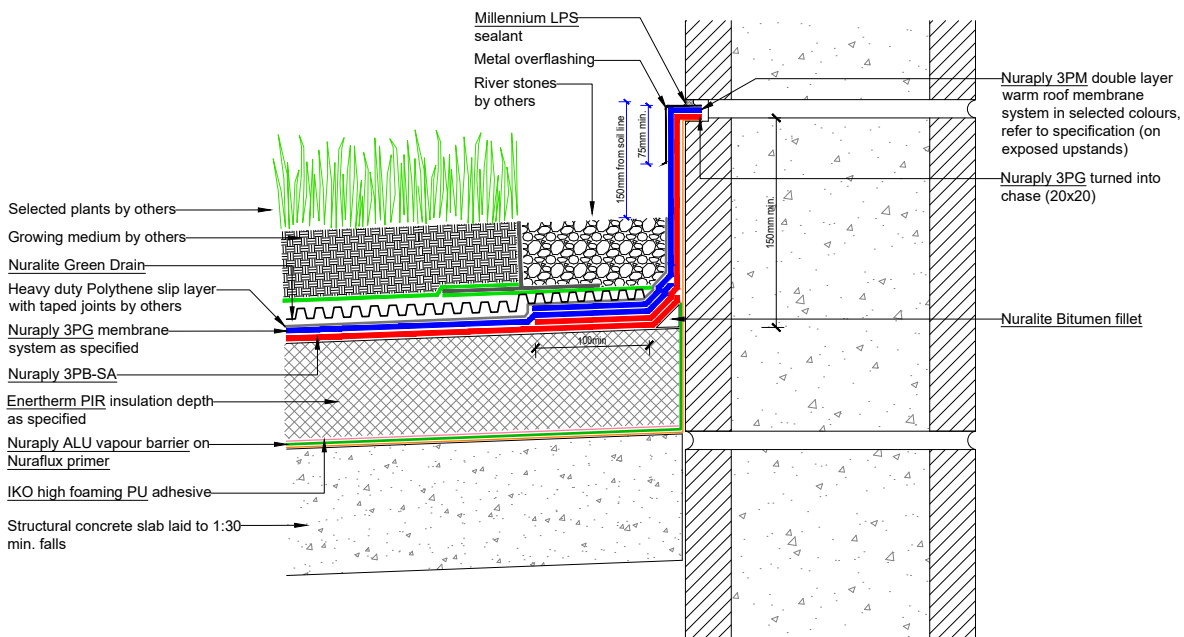

All Nuralite products/systems to be installed by an authorized Nuralite applicator and in accordance with Nuralite published instruction. Product data sheets should be consulted at all times. This drawing is a guide and is not for construction. This detail drawing is to be used only as part of the Nuralite specification package. All drawings are subject to copyright. Unauthorized use is prohibited. © Nuralite Waterproofing Ltd  
0800 - NURALITE (687254) www.nuralite.co.nz

PRODUCT/SYSTEM: **PROTECTED MEMBRANE GREEN ROOF**  
DETAIL: **WARM/GREEN ROOF - NURAPLY 3PM UPSTAND TERMINATION DETAIL**  
SCALE: **NTS** DATE: **SEP 2018** PREVIOUS DWG no: - REVISION: **1** DWG no: **GCP.D2**



This drawing is indicative only and not for construction. This detail depicts Nuralite products and components for correct use as per the installation manual. All other elements are typical only - refer to the designer. Always refer to original colour details when printing.

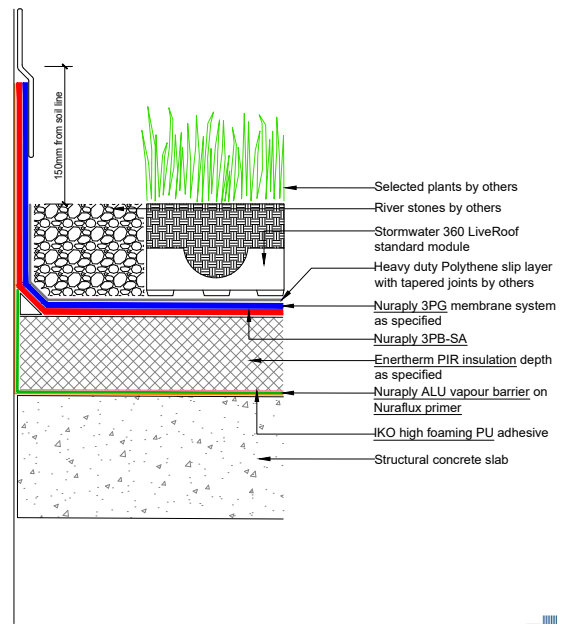
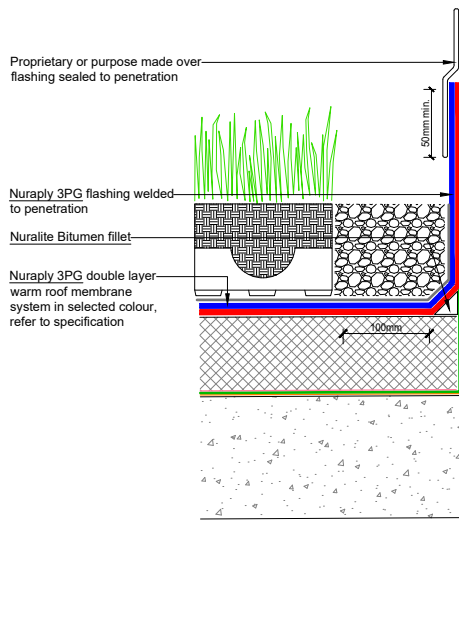

All Nuralite products/systems to be installed by an authorized Nuralite applicator and in accordance with Nuralite published instruction. Product data sheets should be consulted at all times. This drawing is a guide and is not for construction. This detail drawing is to be used only as part of the Nuralite specification package. All drawings are subject to copyright. Unauthorized use is prohibited. © Nuralite Waterproofing Ltd  
0800 - NURALITE (687254) www.nuralite.co.nz

PRODUCT/SYSTEM: **PROTECTED MEMBRANE GREEN ROOF**  
 DETAIL: **WARM/GREEN ROOF - ROOF PENETRATION WITH INTEGRAL FLASHING**  
 SCALE: **NTS** DATE: **SEP 2018** PREVIOUS DWG no: - REVISION: **1** DWG no: **GCP.E1**

This drawing is indicative only and not for construction. This detail depicts Nuralite products and components for correct use as per the installation manual. All other elements are typical only - refer to the designer. Always refer to original colour details when printing.

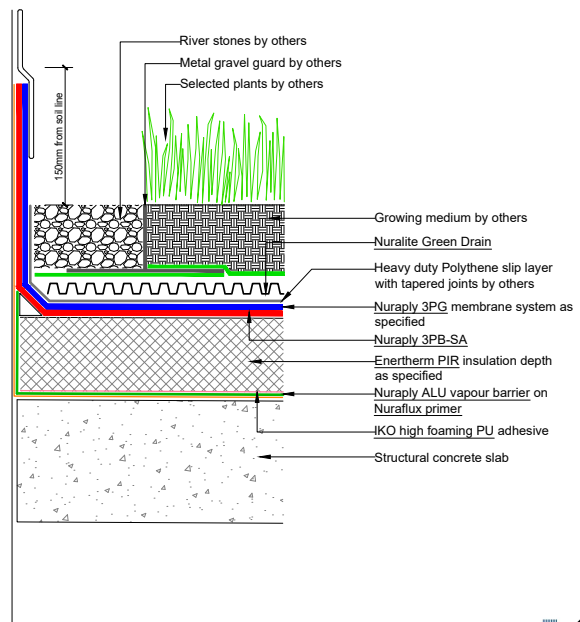
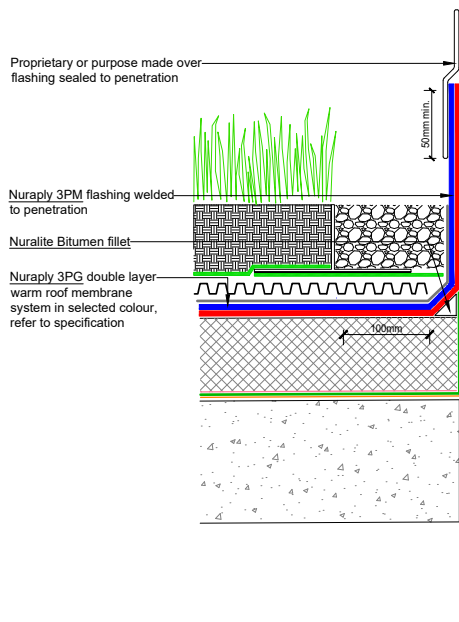

All Nuralite products/systems to be installed by an authorized Nuralite applicator and in accordance with Nuralite published instruction. Product data sheets should be consulted at all times. This drawing is a guide and is not for construction. This detail drawing is to be used only as part of the Nuralite specification package. All drawings are subject to copyright. Unauthorized use is prohibited. © Nuralite Waterproofing Ltd  
0800 - NURALITE (687254) www.nuralite.co.nz

PRODUCT/SYSTEM: **PROTECTED MEMBRANE GREEN ROOF**  
 DETAIL: **WARM/GREEN ROOF - ROOF PENETRATION WITH INTEGRAL FLASHING**  
 SCALE: **NTS** DATE: **SEP 2018** PREVIOUS DWG no: - REVISION: **1** DWG no: **GCP.E2**

This drawing is indicative only and not for construction. This detail depicts Nuralite products and components for correct use as per the installation manual. All other elements are typical only - refer to the designer. Always refer to original colour details when printing.

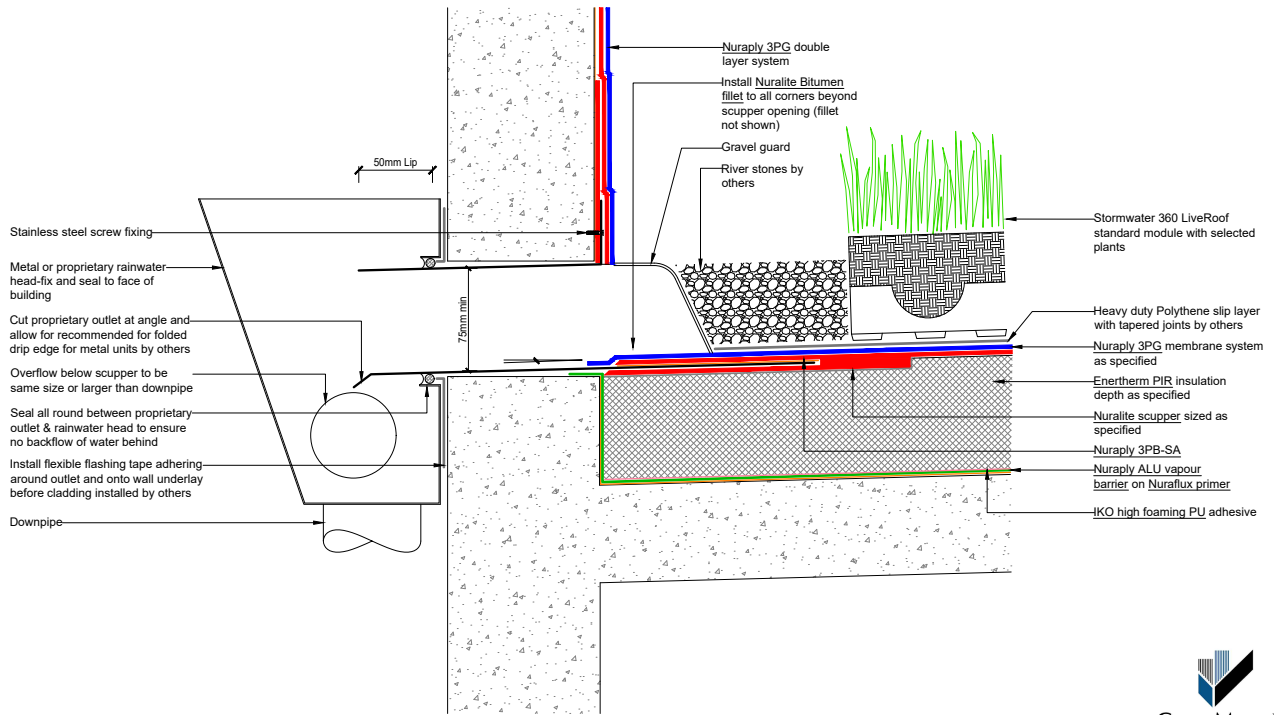

All Nuralite products/systems to be installed by an authorized Nuralite applicator and in accordance with Nuralite published instruction. Product data sheets should be consulted at all times. This drawing is a guide and is not for construction. This detail drawing is to be used only as part of the Nuralite specification package. All drawings are subject to copyright. Unauthorized use is prohibited. © Nuralite Waterproofing Ltd  
0800 - NURALITE (687254) www.nuralite.co.nz

PRODUCT/SYSTEM:	<b>PROTECTED MEMBRANE GREEN ROOF</b>		
DETAIL:	WARM/GREEN ROOF - SCUPPER DETAIL		
SCALE:	NTS	DATE: <b>SEP 2018</b>	PREVIOUS DWG no: - REVISION: <b>1</b> DWG no: <b>GCP.F1</b>

This drawing is indicative only and not for construction. This detail depicts Nuralite products and components for correct use as per the installation manual. All other elements are typical only - refer to the designer. Always refer to original colour details when printing.

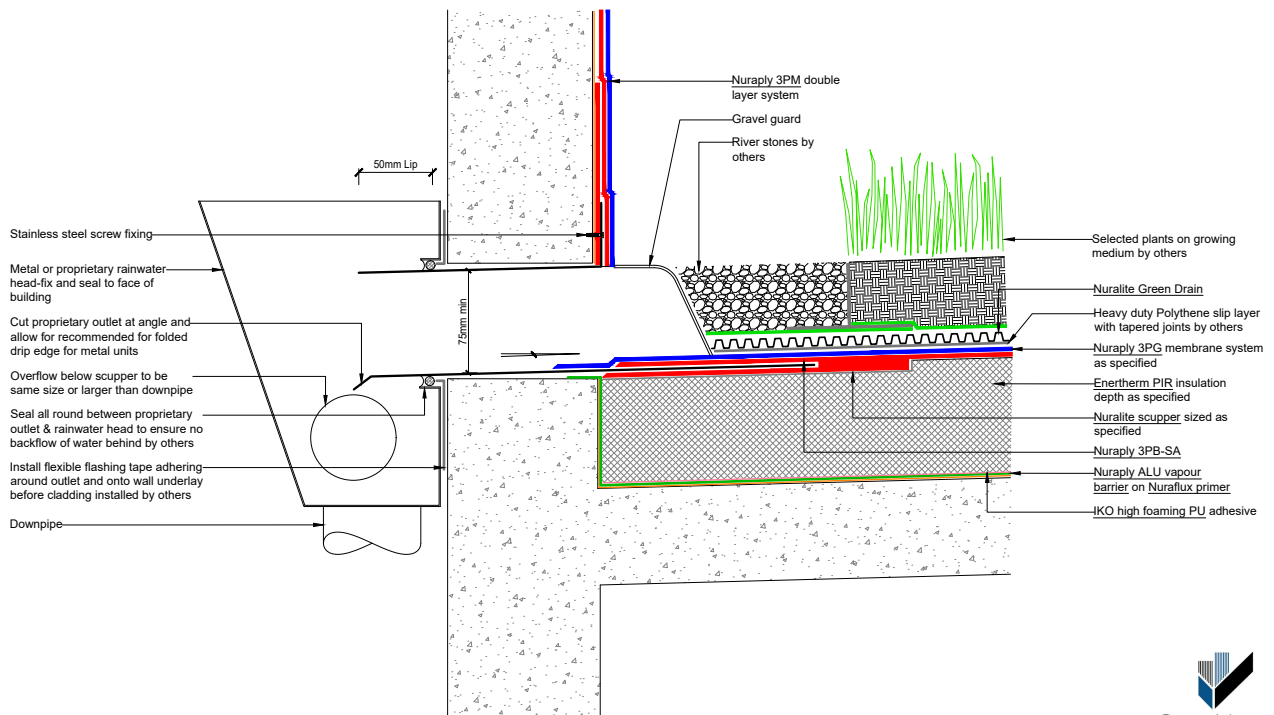

All Nuralite products/systems to be installed by an authorized Nuralite applicator and in accordance with Nuralite published instruction. Product data sheets should be consulted at all times. This drawing is a guide and is not for construction. This detail drawing is to be used only as part of the Nuralite specification package. All drawings are subject to copyright. Unauthorized use is prohibited. © Nuralite Waterproofing Ltd  
0800 - NURALITE (687254) www.nuralite.co.nz

PRODUCT/SYSTEM:	<b>PROTECTED MEMBRANE GREEN ROOF</b>		
DETAIL:	WARM/GREEN ROOF - SCUPPER DETAIL		
SCALE:	NTS	DATE: <b>SEP 2018</b>	PREVIOUS DWG no: - REVISION: <b>1</b> DWG no: <b>GCP.F2</b>

This drawing is indicative only and not for construction. This detail depicts Nuralite products and components for correct use as per the installation manual. All other elements are typical only - refer to the designer. Always refer to original colour details when printing.

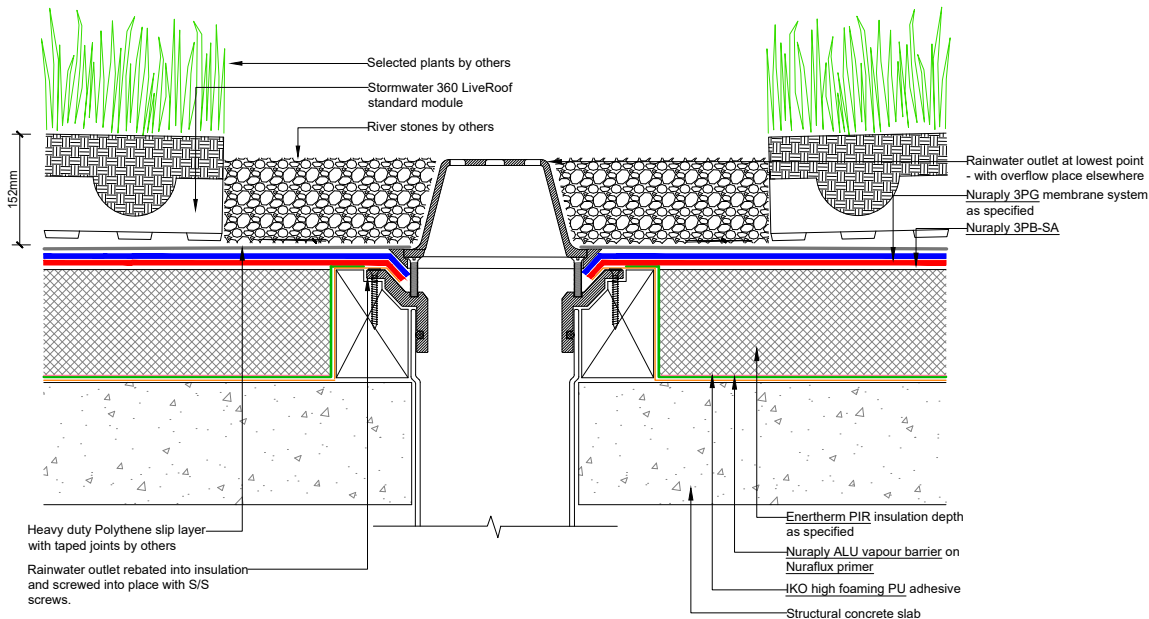

**CODEMARK™**  
CM700033

**NURALITE**  
THE FLAT ROOF EXPERTS



All Nuralite products/systems to be installed by an authorized Nuralite applicator and in accordance with Nuralite published instruction. Product data sheets should be consulted at all times. This drawing is a guide and is not for construction. This detail drawing is to be used only as part of the Nuralite specification package. All drawings are subject to copyright. Unauthorized use is prohibited. © Nuralite Waterproofing Ltd  
0800 - NURALITE (687254) www.nuralite.co.nz

PRODUCT/SYSTEM: **PROTECTED MEMBRANE GREEN ROOF**  
DETAIL: **WARM/GREEN ROOF - LARGE RAINWATER OUTLET**  
SCALE: NTS DATE: **SEP 2018** PREVIOUS DWG no: - REVISION: **1** DWG no: **GCP.G1**

This drawing is indicative only and not for construction. This detail depicts Nuralite products and components for correct use as per the installation manual. All other elements are typical only - refer to the designer. Always refer to original colour details when printing.

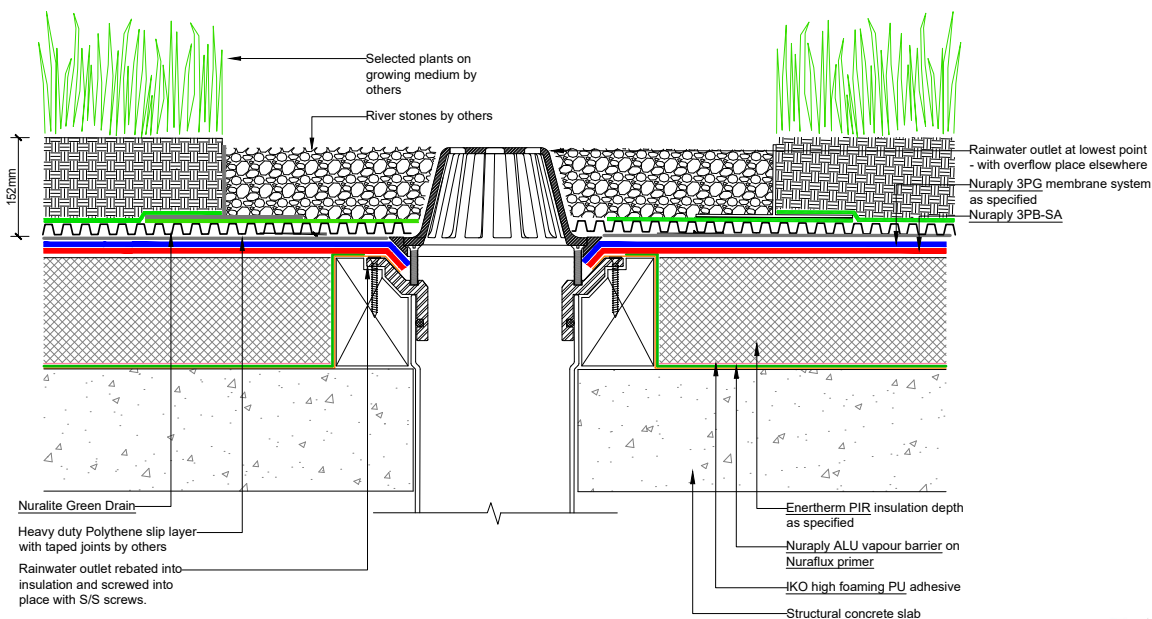

**CODEMARK™**  
CM700033

**NURALITE**  
THE FLAT ROOF EXPERTS



All Nuralite products/systems to be installed by an authorized Nuralite applicator and in accordance with Nuralite published instruction. Product data sheets should be consulted at all times. This drawing is a guide and is not for construction. This detail drawing is to be used only as part of the Nuralite specification package. All drawings are subject to copyright. Unauthorized use is prohibited. © Nuralite Waterproofing Ltd  
0800 - NURALITE (687254) www.nuralite.co.nz

PRODUCT/SYSTEM: **PROTECTED MEMBRANE GREEN ROOF**  
DETAIL: **WARM/GREEN ROOF - LARGE RAINWATER OUTLET**  
SCALE: NTS DATE: **SEP 2018** PREVIOUS DWG no: - REVISION: **1** DWG no: **GCP.G2**

This drawing is indicative only and not for construction. This detail depicts Nuralite products and components for correct use as per the installation manual. All other elements are typical only - refer to the designer. Always refer to original colour details when printing.

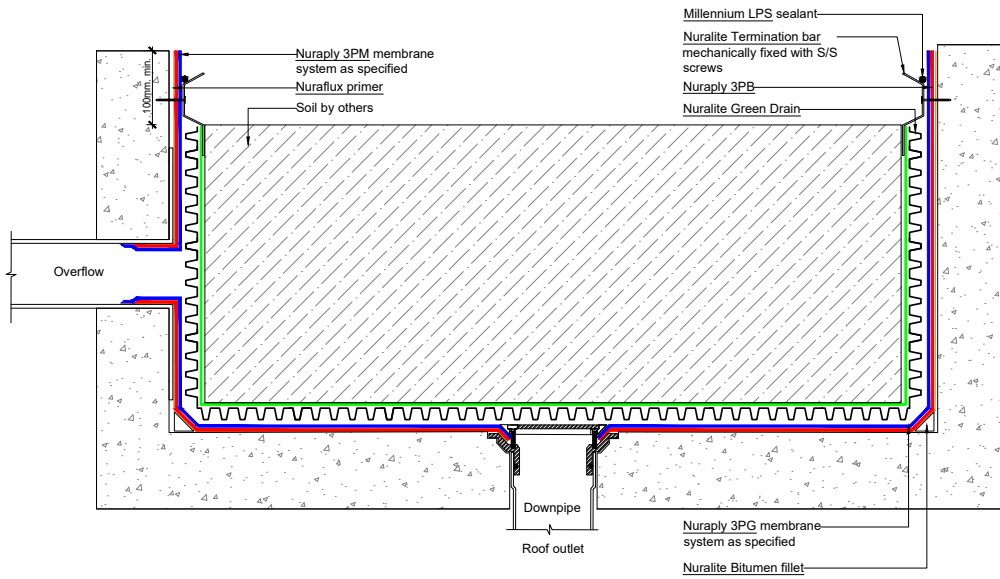

All Nuralite products/systems to be installed by an authorized Nuralite applicator and in accordance with Nuralite published instruction. Product data sheets should be consulted at all times. This drawing is a guide and is not for construction. This detail drawing is to be used only as part of the Nuralite specification package. All drawings are subject to copyright. Unauthorized use is prohibited. © Nuralite Waterproofing Ltd  
0800 - NURALITE (687254) www.nuralite.co.nz

PRODUCT/SYSTEM:	<b>PROTECTED MEMBRANE GREEN ROOF</b>		
DETAIL:	PLANTER DETAIL		
SCALE:	NTS	DATE: <b>SEP 2018</b>	PREVIOUS DWG no: - REVISION: <b>1</b> DWG no: <b>GCP.H1</b>

This drawing is indicative only and not for construction. This detail depicts Nuralite products and components for correct use as per the installation manual. All other elements are typical only - refer to the designer. Always refer to original colour details when printing.

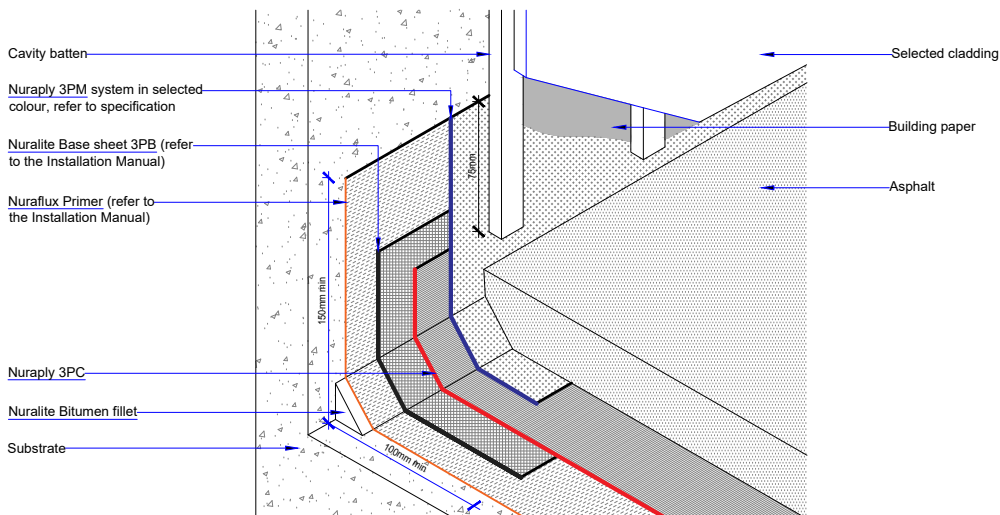

All Nuralite products/systems to be installed by an authorized Nuralite applicator and in accordance with Nuralite published instruction. Product data sheets should be consulted at all times. This drawing is a guide and is not for construction. This detail drawing is to be used only as part of the Nuralite specification package. All drawings are subject to copyright. Unauthorized use is prohibited. © Nuralite Waterproofing Ltd  
0800 - NURALITE (687254) www.nuralite.co.nz

PRODUCT/SYSTEM:	<b>NURALITE 3PC WITH ASPHALT TOPPING</b>		
DETAIL:	UPSTAND BEHIND CAVITY		
SCALE:	NTS	DATE: <b>SEP 2018</b>	PREVIOUS DWG no: - REVISION: <b>1</b> DWG no: <b>CPP.A1 iso</b>

This drawing is indicative only and not for construction. This detail depicts Nuralite products and components for correct use as per the installation manual. All other elements are typical only - refer to the designer. Always refer to original colour details when printing.

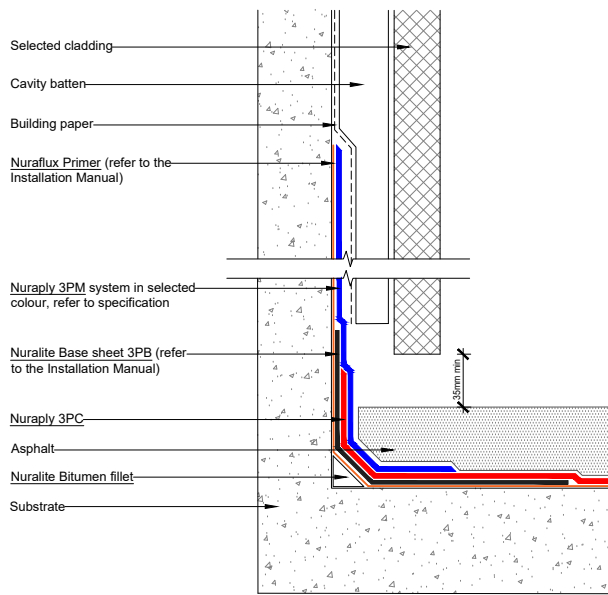

All Nuralite products/systems to be installed by an authorized Nuralite applicator and in accordance with Nuralite published instruction. Product data sheets should be consulted at all times. This drawing is a guide and is not for construction. This detail drawing is to be used only as part of the Nuralite specification package. All drawings are subject to copyright. Unauthorized use is prohibited. © Nuralite Waterproofing Ltd  
0800 - NURALITE (687254) www.nuralite.co.nz

PRODUCT/SYSTEM:	<b>NURAPLY 3PC WITH ASPHALT TOPPING</b>		
DETAIL:	UPSTAND BEHIND CAVITY		
SCALE: NTS	DATE: <b>SEP 2018</b>	PREVIOUS DWG no: -	REVISION: <b>1</b> DWG no: <b>CPP.A1</b>

This drawing is indicative only and not for construction. This detail depicts Nuralite products and components for correct use as per the installation manual. All other elements are typical only - refer to the designer. Always refer to original colour details when printing.

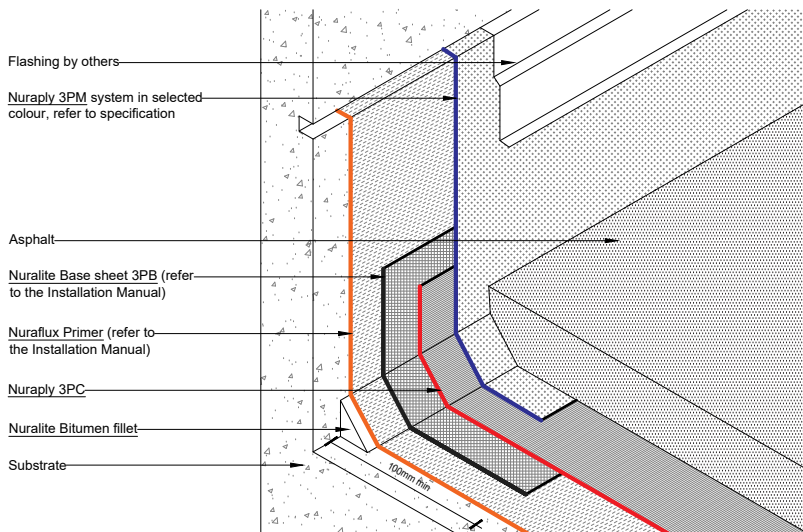

All Nuralite products/systems to be installed by an authorized Nuralite applicator and in accordance with Nuralite published instruction. Product data sheets should be consulted at all times. This drawing is a guide and is not for construction. This detail drawing is to be used only as part of the Nuralite specification package. All drawings are subject to copyright. Unauthorized use is prohibited. © Nuralite Waterproofing Ltd  
0800 - NURALITE (687254) www.nuralite.co.nz

PRODUCT/SYSTEM:	<b>NURAPLY 3PC WITH ASPHALT TOPPING</b>		
DETAIL:	INTO CHASE		
SCALE: NTS	DATE: <b>SEP 2018</b>	PREVIOUS DWG no: -	REVISION: <b>1</b> DWG no: <b>CPP.A2 iso</b>



This drawing is indicative only and not for construction. This detail depicts Nuralite products and components for correct use as per the installation manual. All other elements are typical only - refer to the designer. Always refer to original colour details when printing.

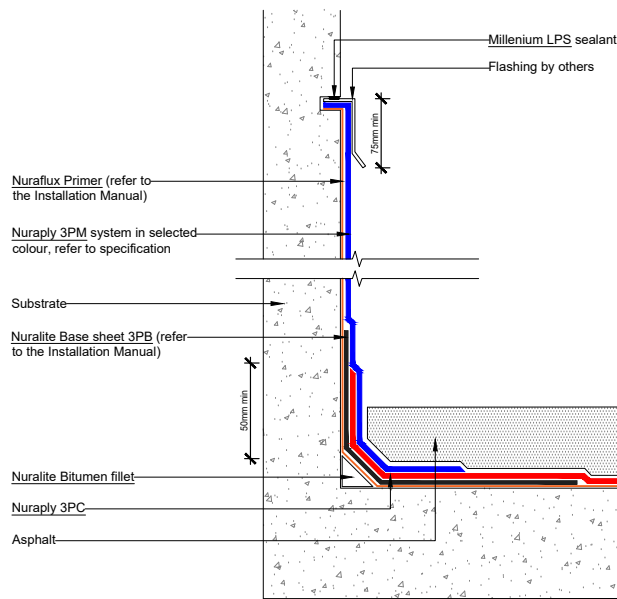

All Nuralite products/systems to be installed by an authorized Nuralite applicator and in accordance with Nuralite published instruction. Product data sheets should be consulted at all times. This drawing is a guide and is not for construction. This detail drawing is to be used only as part of the Nuralite specification package. All drawings are subject to copyright. Unauthorized use is prohibited. © Nuralite Waterproofing Ltd  
0800 - NURALITE (687254) www.nuralite.co.nz

PRODUCT/SYSTEM:	<b>NURAPLY 3PC WITH ASPHALT TOPPING</b>		
DETAIL:	INTO CHASE		
SCALE: NTS	DATE: <b>SEP 2018</b>	PREVIOUS DWG no: -	REVISION: <b>1</b> DWG no: <b>CPP.A2</b>

This drawing is indicative only and not for construction. This detail depicts Nuralite products and components for correct use as per the installation manual. All other elements are typical only - refer to the designer. Always refer to original colour details when printing.

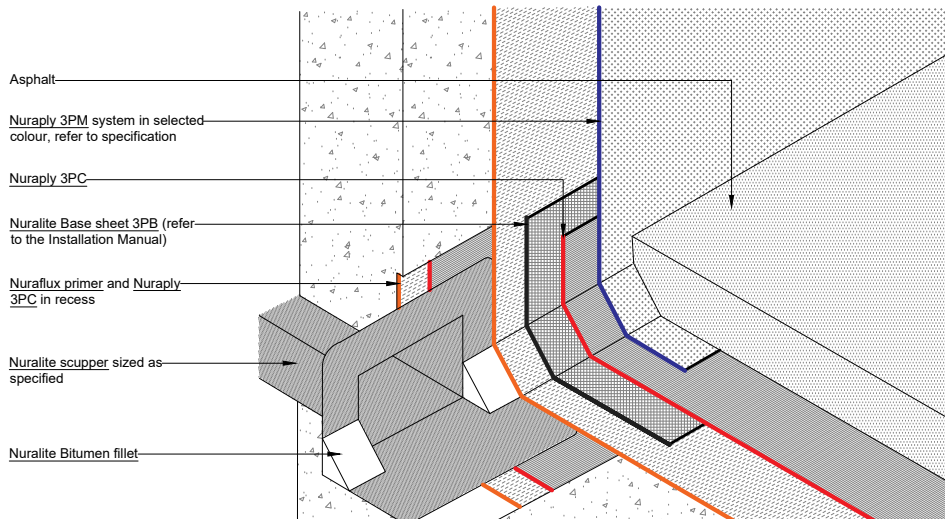

All Nuralite products/systems to be installed by an authorized Nuralite applicator and in accordance with Nuralite published instruction. Product data sheets should be consulted at all times. This drawing is a guide and is not for construction. This detail drawing is to be used only as part of the Nuralite specification package. All drawings are subject to copyright. Unauthorized use is prohibited. © Nuralite Waterproofing Ltd  
0800 - NURALITE (687254) www.nuralite.co.nz

PRODUCT/SYSTEM:	<b>NURAPLY 3PC WITH ASPHALT TOPPING</b>		
DETAIL:	SCUPPER DETAIL		
SCALE: NTS	DATE: <b>SEP 2018</b>	PREVIOUS DWG no: -	REVISION: <b>1</b> DWG no: <b>CPP.A3 iso</b>

This drawing is indicative only and not for construction. This detail depicts Nuralite products and components for correct use as per the installation manual. All other elements are typical only - refer to the designer. Always refer to original colour details when printing.

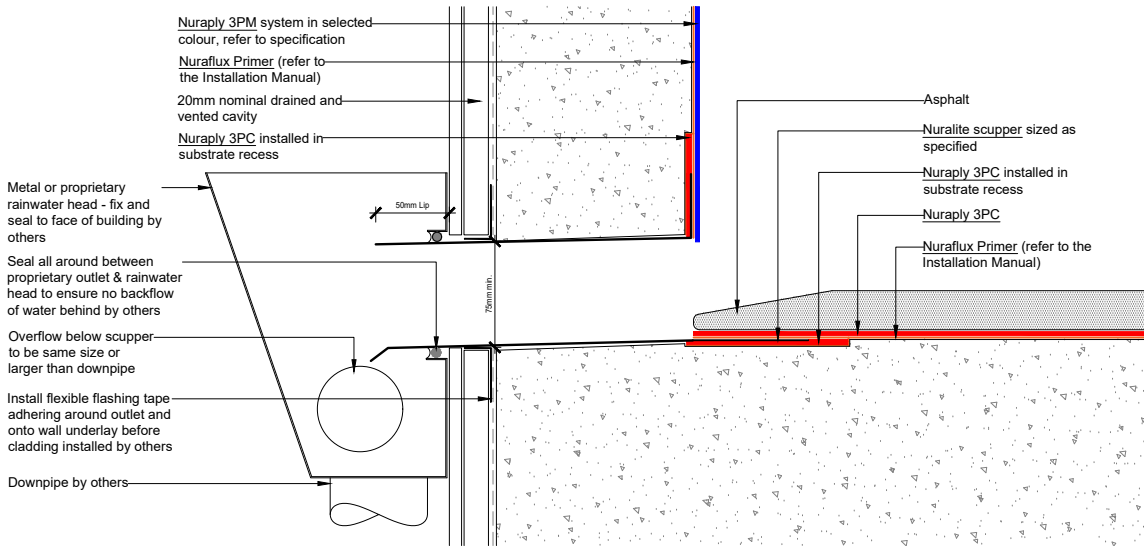

All Nuralite products/systems to be installed by an authorized Nuralite applicator and in accordance with Nuralite published instruction. Product data sheets should be consulted at all times. This drawing is a guide and is not for construction. This detail drawing is to be used only as part of the Nuralite specification package. All drawings are subject to copyright. Unauthorized use is prohibited. © Nuralite Waterproofing Ltd  
 0800 - NURALITE (687254) www.nuralite.co.nz

PRODUCT/SYSTEM:	<b>NURAPLY 3PC WITH ASPHALT TOPPING</b>		
DETAIL:	SCUPPER DETAIL		
SCALE: NTS	DATE: <b>SEP 2018</b>	PREVIOUS DWG no: -	REVISION: <b>1</b> DWG no: <b>CPP.A3</b>

This drawing is indicative only and not for construction. This detail depicts Nuralite products and components for correct use as per the installation manual. All other elements are typical only - refer to the designer. Always refer to original colour details when printing.

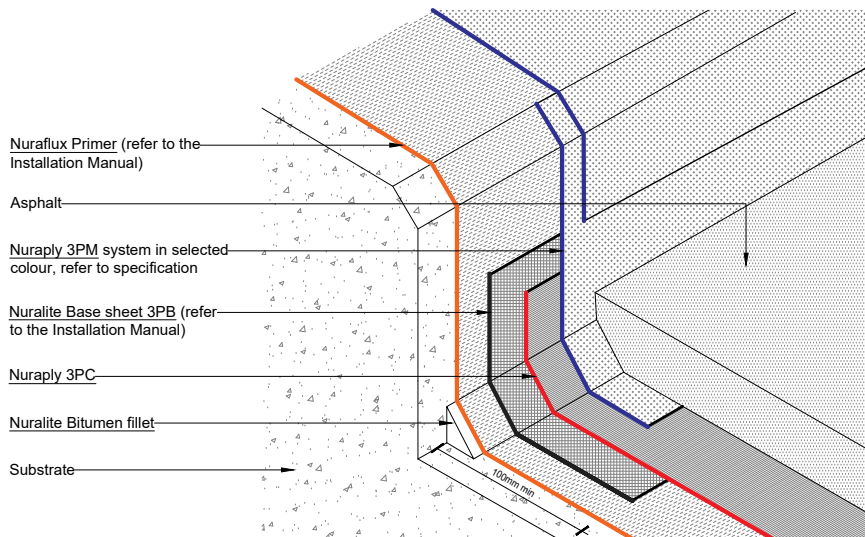

All Nuralite products/systems to be installed by an authorized Nuralite applicator and in accordance with Nuralite published instruction. Product data sheets should be consulted at all times. This drawing is a guide and is not for construction. This detail drawing is to be used only as part of the Nuralite specification package. All drawings are subject to copyright. Unauthorized use is prohibited. © Nuralite Waterproofing Ltd  
 0800 - NURALITE (687254) www.nuralite.co.nz

PRODUCT/SYSTEM:	<b>NURAPLY 3PC WITH ASPHALT TOPPING</b>		
DETAIL:	PARAPET		
SCALE: NTS	DATE: <b>SEP 2018</b>	PREVIOUS DWG no: -	REVISION: <b>1</b> DWG no: <b>CPP.A4 iso</b>





This drawing is indicative only and not for construction. This detail depicts Nuralite products and components for correct use as per the installation manual. All other elements are typical only - refer to the designer. Always refer to original colour details when printing.

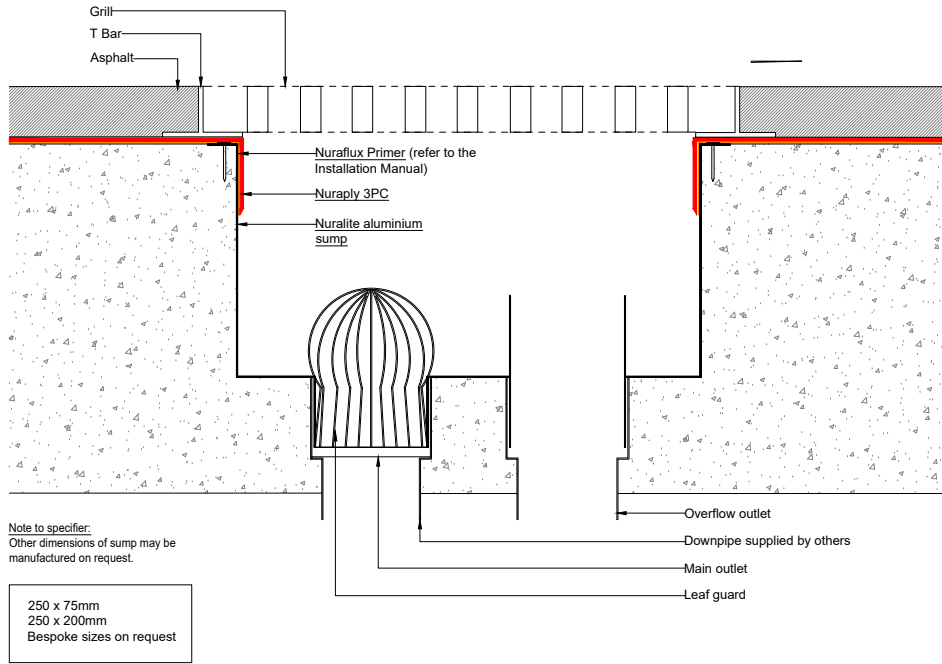

All Nuralite products/systems to be installed by an authorized Nuralite applicator and in accordance with Nuralite published instruction. Product data sheets should be consulted at all times. This drawing is a guide and is not for construction. This detail drawing is to be used only as part of the Nuralite specification package. All drawings are subject to copyright. Unauthorized use is prohibited. © Nuralite Waterproofing Ltd  
0800 - NURALITE (687254) www.nuralite.co.nz

PRODUCT/SYSTEM:	<b>NURAPLY 3PC WITH ASPHALT TOPPING</b>		
DETAIL:	SUMP WITH GRILL		
SCALE:	NTS	DATE: <b>SEP 2018</b>	PREVIOUS DWG no: - REVISION: <b>1</b> DWG no: <b>CPP.B2</b>

This drawing is indicative only and not for construction. This detail depicts Nuralite products and components for correct use as per the installation manual. All other elements are typical only - refer to the designer. Always refer to original colour details when printing.

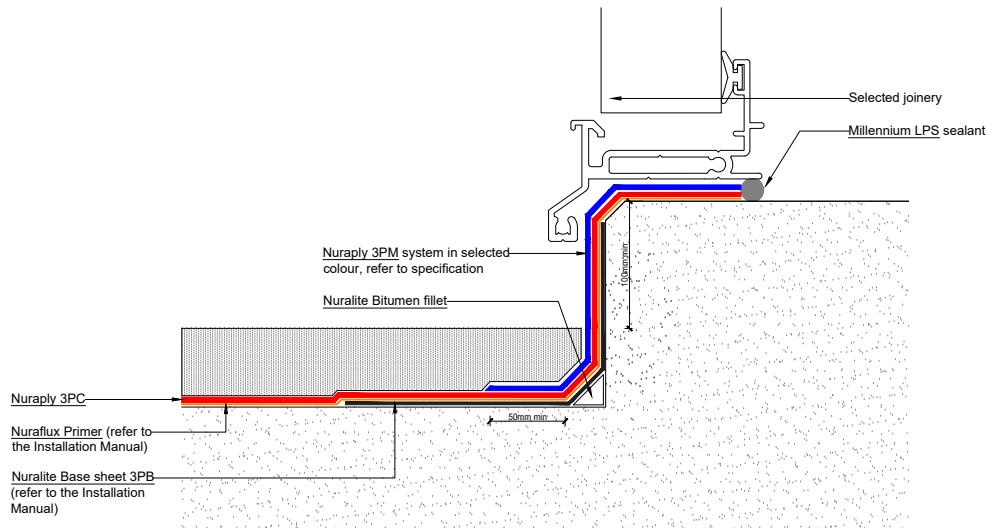

Note: 100mm min from the finished deck height to the top of the finished internal floor level.



All Nuralite products/systems to be installed by an authorized Nuralite applicator and in accordance with Nuralite published instruction. Product data sheets should be consulted at all times. This drawing is a guide and is not for construction. This detail drawing is to be used only as part of the Nuralite specification package. All drawings are subject to copyright. Unauthorized use is prohibited. © Nuralite Waterproofing Ltd  
0800 - NURALITE (687254) www.nuralite.co.nz

PRODUCT/SYSTEM:	<b>NURAPLY 3PC WITH ASPHALT TOPPING</b>		
DETAIL:	DOOR SILL TRANSITION		
SCALE:	NTS	DATE: <b>SEP 2018</b>	PREVIOUS DWG no: - REVISION: <b>1</b> DWG no: <b>CPP.B3</b>

This drawing is indicative only and not for construction. This detail depicts Nuralite products and components for correct use as per the installation manual. All other elements are typical only - refer to the designer. Always refer to original colour details when printing.

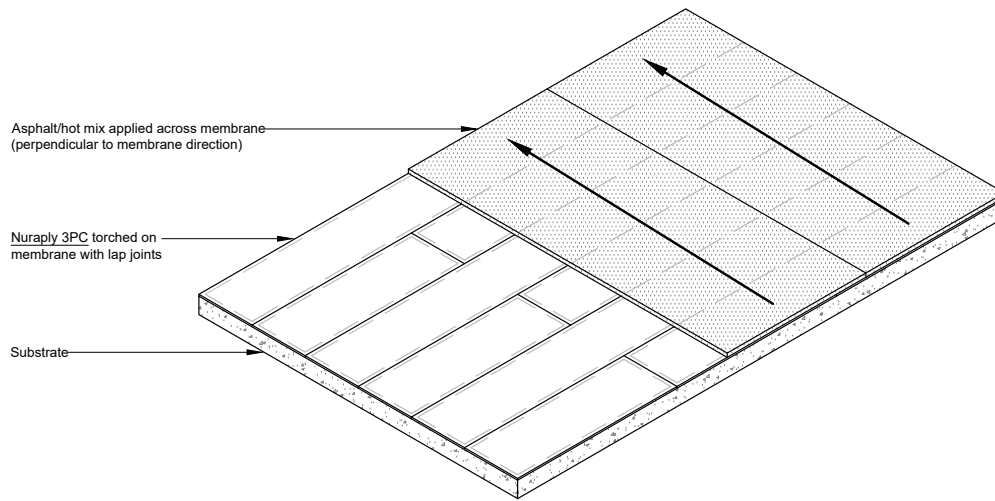

All Nuralite products/systems to be installed by an authorized Nuralite applicator and in accordance with Nuralite published instruction. Product data sheets should be consulted at all times. This drawing is a guide and is not for construction. This detail drawing is to be used only as part of the Nuralite specification package. All drawings are subject to copyright. Unauthorized use is prohibited. © Nuralite Waterproofing Ltd  
0800 - NURALITE (687254) www.nuralite.co.nz

PRODUCT/SYSTEM: **NURAPLY 3PC WITH ASPHALT TOPPING**  
 DETAIL: **MEMBRANE AND ASPHALT/HOTMIX APPLICATION DETAIL**  
 SCALE: NTS DATE: **SEP 2018** PREVIOUS DWG no: - REVISION: **1** DWG no: **CPP.C1**

This drawing is indicative only and not for construction. This detail depicts Nuralite products and components for correct use as per the installation manual. All other elements are typical only - refer to the designer. Always refer to original colour details when printing.

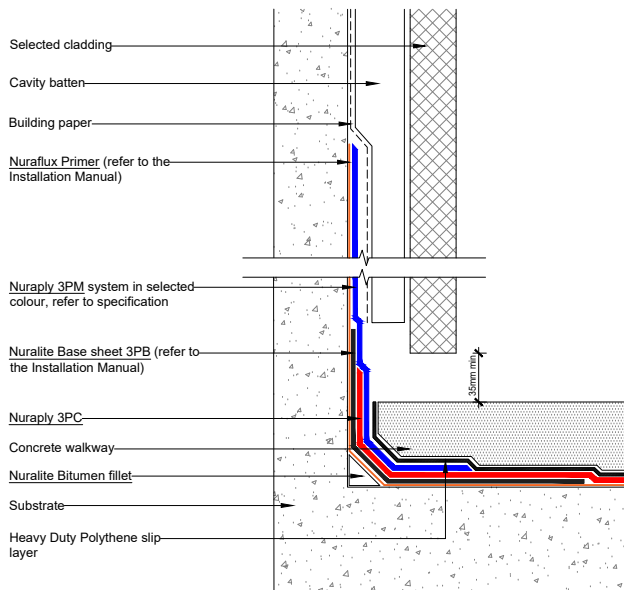

All Nuralite products/systems to be installed by an authorized Nuralite applicator and in accordance with Nuralite published instruction. Product data sheets should be consulted at all times. This drawing is a guide and is not for construction. This detail drawing is to be used only as part of the Nuralite specification package. All drawings are subject to copyright. Unauthorized use is prohibited. © Nuralite Waterproofing Ltd  
0800 - NURALITE (687254) www.nuralite.co.nz

PRODUCT/SYSTEM: **NURAPLY 3PC WITH ASPHALT TOPPING**  
 DETAIL: **UPSTAND BEHIND CAVITY**  
 SCALE: NTS DATE: **SEP 2018** PREVIOUS DWG no: - REVISION: **1** DWG no: **CPP.D1**

This drawing is indicative only and not for construction. This detail depicts Nuralite products and components for correct use as per the installation manual. All other elements are typical only - refer to the designer. Always refer to original colour details when printing.

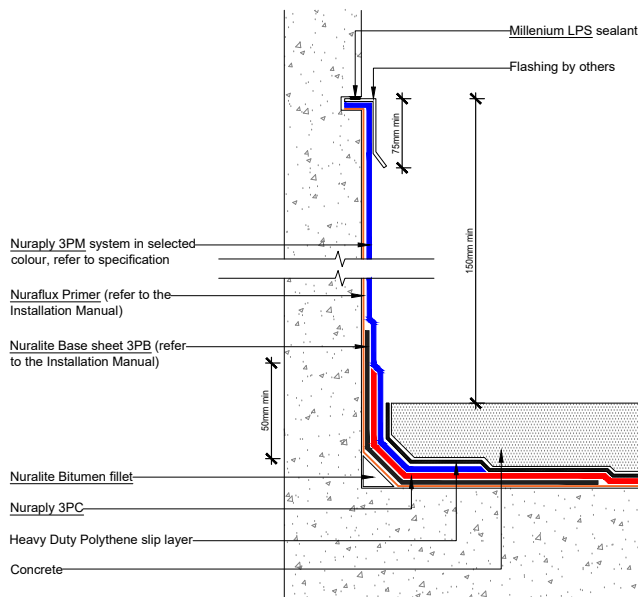

All Nuralite products/systems to be installed by an authorized Nuralite applicator and in accordance with Nuralite published instruction. Product data sheets should be consulted at all times. This drawing is a guide and is not for construction. This detail drawing is to be used only as part of the Nuralite specification package. All drawings are subject to copyright. Unauthorized use is prohibited. © Nuralite Waterproofing Ltd  
0800 - NURALITE (687254) www.nuralite.co.nz

PRODUCT/SYSTEM:	<b>NURAPLY 3PC WITH ASPHALT TOPPING</b>		
DETAIL:	INTO CHASE		
SCALE:	NTS	DATE: <b>SEP 2018</b>	PREVIOUS DWG no: -
REVISION:	<b>1</b>	DWG no: <b>CPP.D2</b>	

This drawing is indicative only and not for construction. This detail depicts Nuralite products and components for correct use as per the installation manual. All other elements are typical only - refer to the designer. Always refer to original colour details when printing.

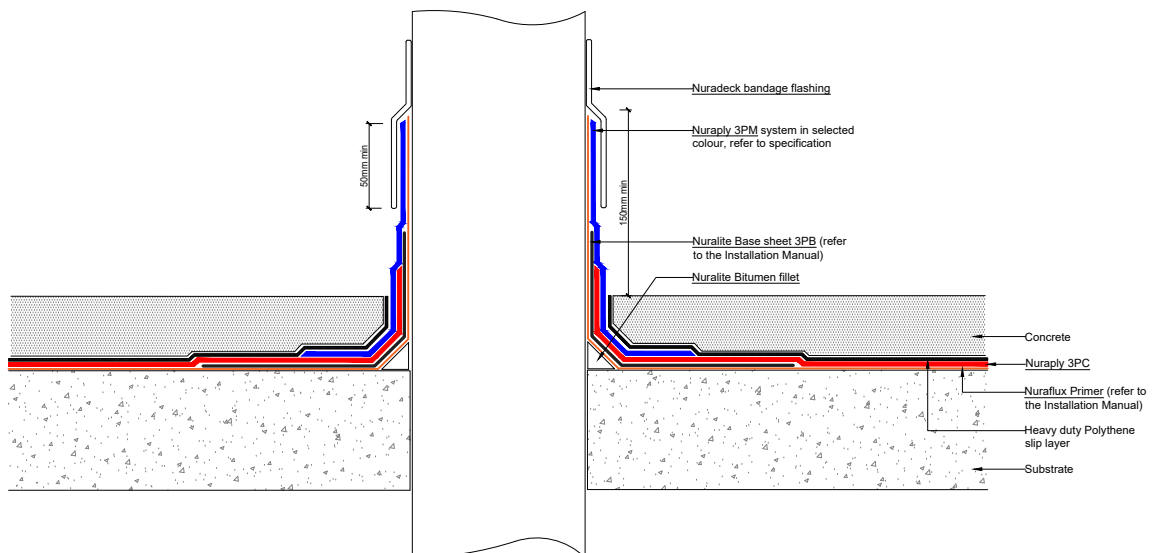

All Nuralite products/systems to be installed by an authorized Nuralite applicator and in accordance with Nuralite published instruction. Product data sheets should be consulted at all times. This drawing is a guide and is not for construction. This detail drawing is to be used only as part of the Nuralite specification package. All drawings are subject to copyright. Unauthorized use is prohibited. © Nuralite Waterproofing Ltd  
0800 - NURALITE (687254) www.nuralite.co.nz

PRODUCT/SYSTEM:	<b>NURAPLY 3PC WITH ASPHALT TOPPING</b>		
DETAIL:	COLD ROOF - POST OR PIPE PENETRATION		
SCALE:	NTS	DATE: <b>SEP 2018</b>	PREVIOUS DWG no: -
REVISION:	<b>1</b>	DWG no: <b>CPP.D3</b>	

This drawing is indicative only and not for construction. This detail depicts Nuralite products and components for correct use as per the installation manual. All other elements are typical only - refer to the designer. Always refer to original colour details when printing.

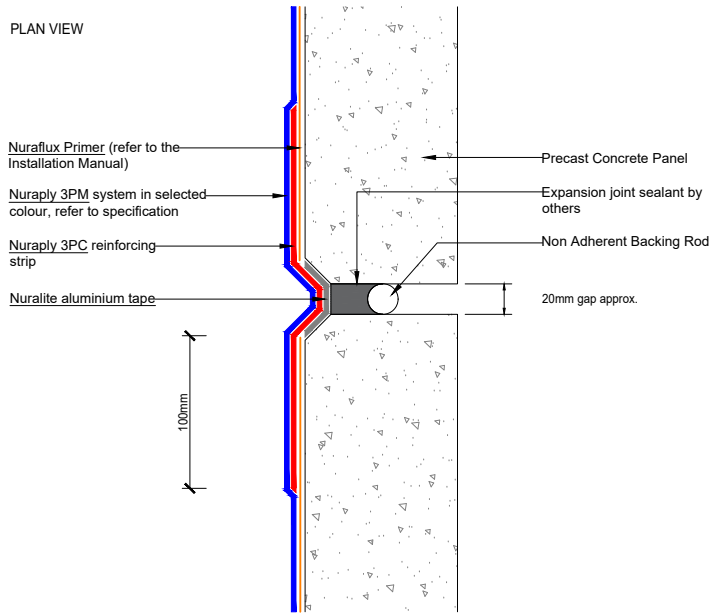

All Nuralite products/systems to be installed by an authorized Nuralite applicator and in accordance with Nuralite published instruction. Product data sheets should be consulted at all times. This drawing is a guide and is not for construction. This detail drawing is to be used only as part of the Nuralite specification package. All drawings are subject to copyright. Unauthorized use is prohibited. © Nuralite Waterproofing Ltd  
 0800 - NURALITE (687254) www.nuralite.co.nz

PRODUCT/SYSTEM:	<b>NURAPLY 3PC WITH ASPHALT TOPPING</b>		
DETAIL:	PRECAST PANEL - MINOR EXPANSION JOINT/TANKING		
SCALE:	NTS	DATE: <b>SEP 2018</b>	PREVIOUS DWG no: -
REVISION:	<b>1</b>	DWG no: <b>CPP.E1</b>	